



PREMIER TILLAGE
Cultivating Greener Tomorrows



9-6 Minimizer Blade Plow

Instruction and Parts Manual

OWNERS MANUAL

MINIMIZER BLADE PLOWS

MMZ 9-54

Weight
24,250

Fold Ht
14'

Fold Width
26'

Working With
54'7"



PREMIER TILLAGE, INC.
2572 Co Rd 76, QUINTER, KANSAS 67752
PHONE 785-754-2381
FAX 785-754-3854
EMAIL: TILL@PREMIERTILLAGE.COM
WWW.PREMIERTILLAGE.COM

TABLE OF CONTENTS

INTRODUCTION.....	1
GENERAL OWNER AND OPERATOR OBLIGATIONS.....	2
SAFETY SIGNAL WORDS	2
IMPLEMENT SAFETY	3
GENERAL SAFETY GUIDELINES.....	3-4
HOW TO INSTALL SAFETY SIGNS	4
TIRE SAFETY.....	5
PERSONAL PROTECTIVE EQUIPMENT	5
BEFORE OPERATION	6
DURING OPERATION	6-7
HIGHWAY AND TRANSPORTATION OPERATIONS	7-8
FOLLOWING OPERATION	9
PERFORMING MAINTENANCE	9-10
HYDRAULIC FLUID AND EQUIPMENT SAFETY.....	11
MAINTENANCE CHART	12
ADDITIONAL USE AND CARE TIPS FROM THE FACTORY	12
OPERATION PROCEDURES	13
TROUBLESHOOTING	14
WARRANTY	15-18
ASSISTANCE	19
WARRANTY REGISTRATION FORM & INSPECTION REPORT	20

INTRODUCTION

Thank you for purchasing a Minimizer blade plow ("Minimizer"). The Minimizer is designed to be pulled behind a ROPS (Roll Over Protective Structure) protected tractor of proper size and horsepower. This Manual is provided as a means of safety and should be fully read and comprehended by the user prior to operation and maintenance. Failure to follow the procedures and requirements described in this Manual may result in personal injury, death, or equipment damages. Premier Tillage, Inc. ("Premier Tillage") has been manufacturing and repairing plows for over 33 years, and has consistently upheld a reputation for quality workmanship. Please contact Premier Tillage if you believe a component has not fulfilled your expectations. These concerns will be handled on a case-by-case basis. For ground engaging and other replaceable parts please contact the parts department.

Information in this Manual is designed to help owners and operators to obtain the best results and safe operation from their investment. The life of any machine depends largely on the care it is given, and the Manual should be read and understood and referred to frequently. If for any reason you do not understand the instructions and safety requirements, please contact your authorized dealer. The intent of this Manual is to provide guidelines to cover general use and to assist in avoiding accidents and injuries.

There may be times when circumstances occur that are not covered in the Manual. At those times it is best to use common sense and contact your authorized dealer or our factory.

The requirements of safety cannot be emphasized enough in this Manual. We urge you to make safety your top priority when using and maintaining the Minimizer. We strongly advise that anyone allowed to operate the equipment be thoroughly trained and tested, to prove they understand the fundamentals of safe operation.

Some photographs, diagrams or illustrations in this Manual may show doors, guards and shields opened or removed to aid clarity and understanding or a particular procedure. All guards, shields and safety devices must be in their proper position prior to operation.

GENERAL OWNER AND OPERATOR OBLIGATIONS:

1. Read this Manual.
2. Register the Minimizer with Premier Tillage within thirty (30) days from the date of purchase, to ensure warranty coverage.
3. Understand the safe and correct operating procedures pertaining to the operation of the Minimizer, as described in this Manual.
4. Lubricate and maintain the Minimizer according to the maintenance schedule in this Manual.
5. Inspect the Minimizer and have parts repaired or replaced when continued use of the Minimizer would cause damage or excessive wear to other parts.
6. Contact the Premier Tillage dealer for repair or replacement of defective parts.

CONSISTENT WITH PREMIER TILLAGE'S POLICY OF CONTINUOUS IMPROVEMENT, PREMIER TILLAGE RESERVES THE RIGHT TO MAKE CHANGES TO THE DESIGN OR ASSEMBLY OF EQUIPMENT WITHOUT OBLIGATION TO MODIFY PREVIOUSLY PRODUCED EQUIPMENT.

Read and understand this Manual and all safety signs before operating and maintaining. Review the safety instructions and precautions annually.

SAFETY SIGNAL WORDS

Note the use of the words **DANGER**, **WARNING** and **CAUTION** with the safety messages. The appropriate signal word for each has been selected using the following guidelines:

DANGER: Indicates an imminently hazardous situation that, if not avoided, will result in death or serious injury. This signal word is to be limited to the most extreme situations typically for machine components which, for functional purposes, cannot be guarded.

WARNING: Indicates a potentially hazardous situation that, if not avoided, could result in death or serious injury, and includes hazards that are exposed when guards are removed. It may also be used to alert against unsafe practices.

CAUTION: indicates a potentially hazardous situation that, if not avoided, may result in minor or moderate injury. It may also be used to alert against unsafe practices.

NOTICE: is used to address safety practices not related to personal safety.

IMPLEMENT SAFETY

1. Read and understand this Manual.
2. Store with implements and wings on the ground.
3. Stop tractor engines before working on or around implementations.
4. Lower wings when working on or around implement.
5. Use all safety road and wing locks during transportation.
6. Use slow moving emblem, or flashing warning lights when transporting.
7. The weight of the towing vehicle must equal or exceed the weight of the towed unit.
8. Transport unit no more than 15 miles per hour on best surfaced roads.
9. Regularly inspect bolts and pins in the hitch, wheels hubs, cylinders, and transport locks.
10. Keep off the implement. Do not stand or walk on tires. Keep riders off implement.

WARNING

Fold cylinder must be charged with oil before unfolding the plow. Unfolding the plow with air in the cylinders may result in extensive damage. Do not remove the lock pins until all hydraulic cylinders and lines are full of oil and free of air.

GENERAL SAFETY GUIDELINES

Safety of the operator and any bystanders is one of the main concerns in designing and developing a new piece of equipment. Designers and manufacturers build in as many safety features as possible. However, every year many accidents occur which could have been avoided by a few seconds of thought and a more careful approach to handling equipment. You, the operator, can avoid accidents by observing the following precautions and insist those working with you, or for you, follow them.

- Replace any **CAUTION, WARNING, DANGER** or instruction safety decal that is not readable or is missing. Location of such decals is indicated in this booklet.
- Do not attempt to operate the equipment under influence of drugs or alcohol. Do not use the equipment if alertness or coordination is impaired.
- Do not read, eat, drink, talk, text, or use a mobile phone while using this equipment.
- This equipment is dangerous to children and persons unfamiliar with its operation. The operator should be a responsible adult familiar with farm machinery and trained in the equipment's operation. **Do not allow any person to operate, assemble, or perform maintenance on the Minimizer until they have read this Manual and developed a thorough understanding of the safety precautions and how the Minimizer works.**

- To prevent injury or death, use a tractor equipped with a Roll Over Protective System (ROPS).
- Do not paint over, remove or deface any safety signs or warning decals on your equipment.
- Observe all safety signs and practice the instructions on them.
- Never exceed the limits of a piece of machinery. If its ability to do a job, or to do so safely, is in question-**DO NOT TRY IT.**
- Stay clear of any moving parts, such as hydraulics cylinders, lift arms, and picker wheels.
- If adjustments need to be made, make them in small steps, shutting down all motion for each adjustment.
- Do not allow anyone to ride on any part of the equipment for any reason.
- Assure that all bystanders are at a safe distance before operating or maintaining the equipment.

REMEMBER: If safety signs have been damaged, removed, become illegible or parts replaced without decals, new decals must be applied. New decals are available from your authorized distributor or factory.

- Keep safety signs clean and legible at all times.
- Replace safety signs that are missing or have become illegible.
- Replaced parts that displayed a safety sign should also display the current sign.
- Safety signs are available from your distributor or dealer parts department or the factory

HOW TO INSTALL SAFETY SIGNS

- Be sure that the installation area is clean and dry.
- Decide on the exact position before you remove the backing paper.
- Remove the smallest portion of the split backing paper.
- Align the decal over the specified area and carefully press the small portion with the exposed sticky backing in place.
- Slowly peel back the remaining paper and carefully smooth the remaining portion of the decal in place.
- Small air pockets can be pierced with a pin and smoothed out using the piece of decal backing paper.

TIRE SAFETY

Failure to follow proper procedures when mounting a tire on a wheel or rim can produce an explosion which may result in serious injury or death. The Minimizer must have Firestone tires 320-70-R15 at all times. If the user puts any other tire on the Minimizer it will void the leveling and rockshaft warranty. The Firestone Radial tire must have 50 LBS of air in the tires to hold the maximum weight.

- Do not attempt to mount a tire unless you have the proper equipment and experience to do the job.
- Inflating or servicing tires can be dangerous. Whenever possible, trained personnel should be called to service and/or mount tires.
- Always order and install tires and wheels with appropriate capacity to meet or exceed the anticipated weight to be placed on the equipment.
- Tire changing can be dangerous and should be performed by trained personnel using the correct tools and equipment.
- When inflating tires, use clip-on chuck extension hose long enough to allow you to stand to one side, NOT in front of or over the tire assembly. Use a safety cage if available.
- When removing and installing wheels, use wheels handling equipment adequate for the weight involved.
- It is the responsibility of the operator to know the lighting and marking requirements of the local highway authorities and to maintain the equipment to provide compliance with the regulations. Add extra lights when transporting at night or during periods of limited visibility.
- Verify that any installed lighting kits are working and clean before transporting.
- Care of the SMV emblem is crucial, verify it is installed and keep it clean and bright

PERSONAL PROTECTIVE EQUIPMENT

- Wear protective clothing and equipment appropriate for the job, such as safety shoes, safety glasses, hard hat and ear plugs.
- Clothing should fit snug without fringes or pull strings to avoid entanglement with moving parts
- Prolonged exposure to loud noises can cause hearing impairment or hearing loss. Wear suitable hearing protection such as earmuffs or earplugs.
- Operating equipment requires the operator's full attention. Avoid wearing radio headphones or earbuds while operating equipment.

BEFORE OPERATION

- Carefully study and understand this Manual.
- Do not wear loose-fitting clothing which may catch in moving parts.
- Always wear protective clothing and substantial shoes.
- Keep wheel lug nuts or bolts tightened to specified torque.
- Assure that agricultural implement tires are inflated evenly.
- Give the unit a visual inspection for any loose bolts, worn parts or cracked welds, and make necessary repairs. Follow the maintenance safety instructions included in this Manual.
- Be sure that there are no tools lying on or in the equipment.
- Do not use the unit when you are unsure that the area is clear, especially children and animals.
- Do not hurry the learning process or take the unit for granted. Ease in it and become familiar with your new equipment.
- Practice operation of your equipment and its attachments. Completely familiarize yourself and other operators with its operation before using.
- Use a tractor equipped with a Roll Over Protective System (ROPS) and fasten your seat belt prior to starting the engine.

DURING OPERATION

- Children should never be allowed on the equipment.
- Never carry riders or allow children to operate equipment.
- Clear the area of small children and bystanders before moving the equipment.
- Securely attach equipment to a towing unit, at the minimum using a hardened 1-1/2" pin, a metal retainer, and safety chains if required. Shift towing unit to a lower gear before going down a steep downgrade, thus using the engine as a retarding force. Keep towing vehicle in gear at all times. Slow down for corners and rough terrain.
- SAFETY CHAINS - If equipment is going to be transported on a public highway, a safety chain should be obtained and installed. Always follow state and local regulations regarding a safety chain and auxiliary lighting when towing farm equipment on a public highway. Be sure to check with local law enforcement agencies for your own particular regulations. Only connection between the towing and towed machines in the event of separation of the primary attaching system.

- Install the safety chain by crossing the chains under the tongue and secure to the draw bar cage or hitch or bumper frame.
- Beware of bystanders, particularly children! Always look around to make sure that it is safe to start the engine of the towing vehicle or move the unit. This is particularly important with higher noise levels and quiet cabs, as you may not hear people shouting.
- **NO PASSENGERS ALLOWED** - Do not carry passengers anywhere on, or in, the tractor equipment, except as required for operation.
- Keep hands and clothing clear of moving parts.
- Always keep all shields and guards in place and securely fastened.
- Do not clean, lubricate or adjust your equipment while it is moving.
- When halting operation, even periodically, set tractor or towing vehicle brakes, disengage the PTO, shut off the engine and **remove the ignition key**.
- Be especially observant of the operating area terrain - watch for holes, rocks or other hidden hazards. Always inspect the area prior to operation.
 - **DO NOT** operate near the edge of drop-offs or banks.
 - **DO NOT** operate on steep slopes, as overturn may result.
 - Operate up and down (not across) intermediate slopes. Avoid sudden starts and stops.

HIGHWAY AND TRANSPORT OPERATIONS

- Adopt safe driving practices.
 - Keep the brake pedals latched together at all times. **NEVER USE INDEPENDENT BRAKING WITH MACHINE IN TOW AS LOSS OF CONTROL AND/OR UPSET OF UNIT CAN RESULT.**
 - Always drive at a safe speed relative to local conditions and ensure that your speed is low enough for an emergency stop to be safe and secure. Keep speed to a minimum.
 - Reduce speed prior to turns to avoid the risk of overturning.
 - Avoid sudden uphill turns on steep slopes.
 - Always keep the tractor or towing vehicle in gear to provide engine braking when going downhill. Do not coast.
 - Do not drink and drive!

- Comply with state and local laws governing highway safety and movement of farm machinery on public roads.
- Use approved accessory lighting flags and necessary warning devices to protect operators of other vehicles on the highway during daylight and nighttime transport. Various safety lights and devices are available from your dealer.
- The use of flashing amber lights is acceptable in most localities. However, some localities prohibit their use. Local laws should be checked for all highway lighting and marking requirements.
- When driving the tractor and equipment on the road or highway under 40 kph (20 mph) at night or during the day, use flashing amber warning lights and a slow-moving vehicle (SMV) identification emblem.
 - Plan your route to avoid heavy traffic.
 - Be a safe and courteous driver. Always yield to oncoming traffic in all situations, including narrow bridges, intersections, etc.
 - Be observant of bridge loading ratings. Do not cross bridges rated lower than the gross weight as which you are operating.
 - Watch for obstructions overhead and to the side while transporting.
 - Always operate equipment in a position to provide maximum visibility at all times. Make allowances for increased length and weight of the equipment when making turns, stopping the unit, etc.
 - Pick the most level route possible when transporting across fields. Avoid the edges of ditches or gullies and steep hillsides.
 - Be extra careful when working on inclines
 - Maneuver the tractor or towing vehicle at safe speeds.
- Avoid overhead wires or other obstacles. Contact with overhead lines could cause serious injury or death.
- Avoid loose fill, rocks and holes; they can be dangerous for equipment operation or movement.
- Allow for unit length when making turns.
- Operate the towing vehicle from the operator's seat only.
- Never stand alongside of unit with engine running or attempt to start engine and/or operate the machine while standing alongside of unit.
- Never leave running equipment attachments unattended.
- As a precaution, always recheck the hardware on equipment following every 100 hours of operation. Correct all problems. Follow the maintenance safety procedures.

FOLLOWING OPERATION

- Following operation, or when unhitching, stop the tractor or towing vehicle, set the brakes, disengage the PTO and all power drives, shut off the engine and **remove the ignition keys**.
- Clean, inspect, service and make necessary repairs to the equipment when parking it for long periods of time or at the end of a working season. This will help ensure that the unit will be ready for use the next time you hook up to it.
- Store the unit in an area away from human activity.
- Do not park equipment where it will be exposed to livestock for long periods of time. Damage and livestock injury could result.
- Do not permit children to play on or around the stored unit.
- Make sure all parked machines are on a hard, level surface and engage all safety devices.
- Wheel chocks may be needed to prevent the unit from rolling.

PERFORMING MAINTENANCE

- Do not allow anyone to perform maintenance on this equipment who has not been properly trained in its safe operation.
- Good maintenance is your responsibility. Poor maintenance is an invitation to trouble. Proper servicing and adjustments are key to the long life of any implement. With careful inspection and routine maintenance, costly repairs can be avoided.
- Some parts and assemblies can be quite heavy. Before attempting to unfasten any part or assembly, arrange to support it by means of a hoist, by blocking or by use of an adequate arrangement to keep it from falling, tipping, swinging or moving in any manner which may hurt somebody or damage the equipment.
- Always use lifting equipment that is adequately rated to do the job. Never lift equipment over people.
- Make sure there is plenty of ventilation. Never operate the engine of the towing vehicle in a closed building. The exhaust fumes may cause asphyxiation.
- Before working on the equipment, stop the towing vehicle, set the brakes, disengage the PTO and all power drives, shut off the engine and **remove the ignition keys**.

- Be certain all moving parts on attachments have come to a complete stop before attempting to perform maintenance.
- **ALWAYS** use a safety support and block the wheels. Never use a jack to support the equipment.
- Always use the proper tools or equipment for the job at hand.
- Use extreme caution when making adjustments.
- Never replace hex bolts with less than grade (5) five bolts unless otherwise specified.
- After servicing, be sure all tools, parts and service equipment are removed
- Where replacement parts are necessary for periodic maintenance and servicing, genuine factory replacement parts must be used to restore your equipment to original specifications. The manufacturer will not claim responsibility for use of unapproved parts and or accessories and other damages as a result of their use.
- If equipment has been altered in any way from original design, Premier Tillage does not accept any liability for injury or warranty.
- Do not alter the equipment or replace parts with other brands. Doing so can cause the equipment to perform improperly and may lead to breakage causing injury or death.
- If repairs require the use of a torch or electric welder, be sure that all flammable and combustible materials are removed.
- Do not weld or cut on any tanks containing oil, fuel or their fumes or other flammable material, or any container whose previous contents are unknown.
- Cleaning solvents should be used with care. Petroleum based solvents are flammable and present a fire hazard. Do not use gasoline. All solvent must be used with adequate ventilation and their vapors should not be inhaled.

HYDRAULIC FLUID AND EQUIPMENT SAFETY

Only adequately trained and qualified persons should work on hydraulics systems. You and other persons may be severely injured or killed by being crushed under a falling piece of equipment. Always have transport locks in place and frame sufficiently blocked when working on any implement.

Hydraulic fluid escaping under pressure can have sufficient force to cause injury. Keep all hoses and connections in good serviceable condition. Failure to heed may result in serious personal injury or death. Escaping hydraulic fluid under pressure can have sufficient pressure to penetrate the skin causing serious injury. Avoid the hazard by relieving the pressure before disconnecting lines or performing work on the system.

Make sure hydraulic fluid connections are tight and all hydraulic hoses and lines are in good condition before applying pressure to the system. Use a piece of paper or cardboard, **NOT BODY PARTS**, to check for suspected leaks. Wear protective gloves and safety glasses or goggles when working with hydraulic system. **DO NOT DELAY!** If an accident occurs, seek immediate medical attention. Any fluid injected into the skin or eyes must be treated within a few hours or gangrene may result.

Always secure equipment with solid supports before working on or under it. Never work under equipment supported by hydraulics. Hydraulics can drop equipment if controls are actuated or hydraulic lines burst or pressure is lost while disconnecting lines. Either situation can drop machinery instantly even when power to hydraulics is off. Do not attempt to disconnect a hydraulic cylinder or hose while the system is under pressure!

Check hydraulic hoses and fittings frequently. Brush and other debris can damage hoses and fittings. Inspect and maintain equipment daily. Loose, broken and missing hardware can cause equipment to not perform properly and can result in bodily injury or death.

Hydraulic systems and oil can be hot and cause burns. Before working on any system, wait until the oil has cooled.

Keep body and body extremities away from areas such as pivot points and hydraulic cylinders. Always secure equipment pivot points to assure they will not move when working on or near them.

MAINTENANCE CHART

TIME	INTERVAL
Check tire pressure	Before Transporting
Grease wheel bearings	Annually
Grease zerk- front wheel assembly	Annually
Review safety instructions	Annually

ADDITIONAL USE AND CARE TIPS FROM THE FACTORY

1. Inspect and grease the picker bearings, grease as needed and at the maximum every 1,200 acres.
2. Inspect and grease the wheel bearings one (1) time per season.
3. Inspect hydraulic hoses/cylinders for leakage at least once per year.
4. If needed, adjust the hitch, by the front two hitch adjustment bolts, until the plow is level.
5. Inspect tire condition and inflate the tires to 50 PSI before each use.
6. Phasing - do not re-phase the machine for more than ten (10) seconds or serious damage could occur to the hydraulic system.
7. Inspect and check the leveling bolt to ensure that it is still tight, prior to each use.
8. Inspect the hazard light operation prior to roading.

OPERATION PROCEDURES

1. Before leveling the Minimizer **Phase the lift cylinder**
 - a. Run the hydraulics in the lift position for 12 seconds
 - b. Run the hydraulics in the down position for 10 seconds

Repeat this process 3 times to ensure that all cylinders are phased completely. Perform at the beginning of each workday and several times throughout the day.

2. Once the Minimizer is phased make sure to check the **leveling of the hitch** to the tractor
 - a. Set the machine in the ground 3"
 - b. Set bubble level on the center frame of Minimizer
 - i. If level, leave hitch as is
 - ii. If not level, move the hitch adjustment bolts on the front of the center frame until level

3. To level the Minimizer

The minimizer is leveled at our factory prior to delivery. Premier Tillage does offer a complimentary level in the first few days of field work. We require that you work at least 200 acres to ensure the blades are scoured before we come to level the Minimizer.

To self-level:

- a. Phase the lift cylinder by repeating step 1 listed above.
- b. You will need a tape measure and laser level. Place the laser level on top of frame, making sure it is on a clean surface. Measure from top of frame to the top of the axle tube on the rockshaft. Make sure the tape measure is on the top dead center of the axle tube and straight up and down.
- c. Set the remaining axles to the same measurement by adjusting the depth adjustment anchor bolt.

4. To Level the standards:

Standards are set level when the Minimizer is assembled. If the standards are no longer level, follow these steps.

- a. You will need a tape measure, a laser level, and 1/16" square slotted shims.
- b. Measure the left leg, right leg, and the front center of the standard. These 3 measurements need to be within an 1/8" of each other.
- c. If the 1/2" measurement is not achievable the standard needs to be replaced.

Replacing Standard

- i. Remove the three bolts on top of the standards.
- ii. Keep the shims separate based on their placement (top, bottom, sides). Also keeping the original shims separate from shims manually added.
- iii. Place the shims on the new standard in the same location as previously removed.
- iv. Tighten all bolts.
- v. Repeat the standard leveling procedure.

5. Replacing a depth adjustment bolt

- a. If a depth adjustment bolt is broken or faulty, remove by taking the rod end cylinder pin out by loosening the bolt to remove the pin.
- b. Once the pin is removed, remove the bolt and transfer all hardware to the new bolt.
- c. Replace bolt and replace pin with bolt still loose.
- d. Repeat step 3 to ensure the plow is level

TROUBLESHOOTING

- When working with the machine and it is making a ridge or a furrow either behind the standard upright or where the standards overlap the first thing to check that the Minimizer is completely phased out by repeating step 1, if the problem is still present then checking the leveling of the axels is necessary then you can achieve this by completing step 3 and if the problem still ensues check the level of the standard by completing step 4 on the problem standards.
- If the Minimizer will not fold all the way up (9-6 and 11-6 only) and the lever is being held for an extended period of time there is a valve that need to be adjusted this valve is on the front fold cylinder of the last fold to adjust this valve you will need wrenched and hex wrenches first remove the cap on top of this valve, second loosen the set screw by using the hex head screw to hold it while you loosen the set screw once the set screw is loose rotate the hex screw clockwise to tighten it, rotate the screw in small increments till the machine will fold.
- If a hydraulic line on the lift fails remove the faulty hose get the exact hose length and ends made replace them with the new hose once this is achieved there will be air in the line of the fazing cylinders lift the Minimizer into the up position the machine will not come up level to make the machine level repeat step 1 till the machine comes up level you may continue to work with the machine once this is achieved but keep periodically re-faze the system throughout the day to ensure that the air is completely out of the system.

If there is anything else wrong with the machine, please let us know
We are always available to help in any way, our service crew is happy to help
Our Office number is 785-754-2381
TJ Hawkins 785-299-0733
Brandon Tommer 785-979-5407
Tyrel Chupp 785-656-0202

LIMITED WARRANTY - OVERVIEW

Premier Tillage provides a limited warranty on each new Minimizer and certain of its component parts and attachments thereto. The limited warranty is a written guarantee by Premier Tillage, which promises to repair or replace the Minimizer, or certain component parts or attachments on the Minimizer, which are found to be defective in materials or workmanship. Please carefully review this section of the Manual because it contains the specific terms and conditions of Premier Tillage's limited warranty, including potential exclusions. The limited warranty applies only to Minimizers sold by an authorized Premier Tillage dealer.

DESCRIPTION OF LIMITED WARRANTY

Premier Tillage warrants to the original purchaser of the Minimizer ("Owner") that the Minimizer frame will be free from defects in materials and workmanship, and will perform according to specifications, subject to the exceptions stated below. The warranty coverage runs for a period of one (1) year, beginning on the date that the Minimizer is delivered to Owner's possession; provided, however, that the warranty is not valid unless the Minimizer is registered with Premier Tillage within thirty (30) days from the date of original purchase.

Except as otherwise provided herein, component parts of the Minimizer, and attachments thereto, are not subject to Premier Tillage's one (1) year limited warranty, and are exclusively covered under Premier Tillage, Inc's limited thirty (30) day warranty, and any applicable original manufacturer's warranty, as described below. These component parts and attachments include, but are not limited to (hereinafter "Component Parts"):

- Bearings
- Seals
- Lights
- Cylinders
- Hydraulic fittings and hoses
- Picker springs
- Blades
- Coulter blades
- Tires and rims
- Rockshaft bearings
- All ground engaging parts not otherwise specified herein.

Premier Tillage provides a limited thirty (30) day warranty on Component Parts, beginning on the same date that the one (1) year limited warranty coverage commences on the Minimizer. After the expiration of the thirty (30) day warranty, Component Parts are warranted only to the extent of the original manufacturer's warranty, if any. To the extent that Premier Tillage manufactures any of the Component Parts, the exclusive warranty on such Component Parts shall be the limited thirty (30) warranty set forth in this section.

In order for a defect to be covered by Premier Tillage's limited warranty, the defect must occur within the applicable warranty period.

WHAT PREMIER TILLAGE WILL DO

If a defect arises during the applicable warranty period that is covered by Premier Tillage's limited warranty, Premier Tillage will, at its sole option, repair or replace the Minimizer or defective part(s). The repair or replacement will be made at no charge for either the part or the labor to repair or replace that part. Warranty work will commence upon owner's delivery of the Minimizer, or defective part(s), to Premier Tillage, or a location designated by Premier Tillage. Premier Tillage shall not be responsible for the cost of transporting the Minimizer or defective part(s) for purposes of Premier Tillage's warranty work. Repairs or replacements must be completed by Premier Tillage, unless otherwise authorized by Premier Tillage, in writing. Performance of warranty work by unauthorized personnel may void the warranty coverage.

PREMIER TILLAGE'S RIGHT TO INSPECT

Premier Tillage reserves the right to inspect the Minimizer or part(s) to determine if a defect in materials or workmanship exists prior to the commencement of any repair or replacement work. Owner is responsible for delivering the Minimizer or part(s) to Premier Tillage, or to a location designated by Premier Tillage, for the inspection, unless otherwise agreed.

OWNER'S RESPONSIBILITIES

Owner is responsible to maintain the Minimizer in accordance with the instructions provided in this Manual, and Premier Tillage reserves the right to require proof that the maintenance instructions have been followed.

Owner is also responsible for operating the Minimizer in a safe manner, and for using the Minimizer only for the purpose for which it was designed. If a defect in the materials or workmanship occurs, Owner must immediately cease operating the Minimizer until repairs are made. Damage which occurs from continued operation after a defect or failure is observed may not be covered by this warranty. Owner shall contact Premier Tillage immediately so that repair or replacement can be made in a timely manner.

WHAT THE LIMITED WARRANTY DOES NOT COVER

Premier Tillage's limited warranty does not cover the repair or replacement of expendable parts, such as pins, nuts, bolts, lubricants, or fluid, unless such items are clearly established to have been defective prior to first use of the Minimizer.

Further, Premier Tillage's limited warranty does not cover failures, damages, or problems caused by, or arising from, any of the following:

- Collision, fire, theft, vandalism, explosion, lightning, earthquake, windstorm, hail, water, flood, or any other Acts of God.
- Abuse or misuse of the Minimizer.
- Accidental or negligent damage by the Owner or any other person.

- Alterations or modifications of the Minimizer, or use of unapproved attachments, which are not authorized by Premier Tillage, in writing.
- Neglected, improper, or incorrect maintenance or operation as outlined in this Manual.
- Failure to maintain property levels of fluids and lubricants.
- Repairs or replacements made by non-authorized persons or persons unaffiliated with Premier Tillage.
- Use of the Minimizer in soils with rocks, stumps, or other obstructions.
- Use of the Minimizer at speeds in excess of 9 miles per hour while the Minimizer is in use.
- Use of the Minimizer at speeds in excess of 25 miles per hour in transport.
- Use of the Minimizer in a manner that is contrary to the intended purpose of the Minimizer.

Furthermore, Premier Tillage's warranty does not cover, and Owner shall be solely responsible for, costs, expenses, and damages, attributable to:

- Pickup or delivery of the Minimizer, or transportation of the Minimizer from Owner's location.
- Rental of replacement equipment during the repair period.
- Overtime labor charges.
- Travel time or mileage.
- Service calls.
- Repairs or replacements other than those performed directly by Premier Tillage and its authorized agents and representatives.
- Crop loss, losses caused by planting or harvest delays, or any expense or loss of labor.

LIMITATIONS AND EXCLUSION OF OTHER WARRANTIES

Owner's sole and exclusive remedy against Premier Tillage, and Premier Tillage's sole obligation for any and all claims related to the Minimizer, or use or operation thereof, whether for breach of contract, warranty, tort (including negligence), or otherwise, shall be limited to Premier Tillage's repair or replacement of the Minimizer or defective parts in accordance with the limited warranty described herein. Without limiting the foregoing, Premier Tillage shall not be liable for consequential, special, incidental, contingent, economic, direct, or indirect damages whatsoever, even if damages are caused by the negligence or fault of Premier Tillage. The limited warranties described herein are exclusive and in lieu of all other express and implied warranties including, but not limited to, the implied warranties of merchantability and fitness for a particular purpose. Premier Tillage does not authorize any person to create for Premier Tillage any obligation or liability other than that stated in the limited warranty described herein.

HOW TO OBTAIN WARRANTY SERVICE

To obtain warranty service under the terms and conditions of the Premier Tillage limited warranty, the Owner must notify Premier Tillage within ten (10) days after observing the defect. Failure to timely notify Premier Tillage may void the warranty coverage. Warranty claims may be submitted to Premier Tillage by telephone, by calling (785) 754-2381, or by submitting written notification to Premier Tillage, Inc. at 301 Park St, PO Box 207, Quinter, Kansas 67752. Before calling or writing, please have the following information ready:

1. Owner's name, address, and telephone number;
2. Product model and serial number;
3. Date of purchase; and
4. Detailed description of the problem.

In those cases in which it is inconvenient to deliver the Minimizer or part to Premier Tillage, the warranty repairs may be made by Premier Tillage at Owner's location, in Premier Tillage's sole discretion. However, if Premier Tillage elects to furnish warranty repair services at Owner's location, Premier Tillage may charge for pickup and delivery, or for travel time and mileage. These charges are not covered under the limited warranty and are the Owner's responsibility, unless agreed to or as required by law.

TRANSFERABILITY

If you decide to sell your Minimizer, any remaining warranty coverage may only be transferred to the new owner with the prior written consent of Premier Tillage. Please contact Premier Tillage to discuss any proposed transfer of ownership.

ASSISTANCE

If you have questions not answered in this manual, or require additional copies, or the manual is damaged, please contact your dealer or:

**PREMIER TILLAGE, INC.
SERVICE DEPARTMENT
2572 Co Rd 72, Quinter KANSAS 67752
PHONE 785-754-2381
FAX 785-754-3854
EMAIL: TILL@PREMIERTILLAGE.COM
WWW.PREMIERTILLAGE.COM**

For all other service inquiries please call:

**Brandon: 785-979-5407
TJ: 785-299-0733
Tyrel: 785-656-0202**

WARRANTY REGISTRATION

This form must be filled out by the dealer and signed by both dealer and customer at time of delivery.

Customer name _____ Dealer name _____

Address _____ Address _____

City, state, zip code _____ City, state, code _____

Customer Phone number (____) _____

Customer home number (____) _____

Customer Email _____ Build Date _____

Model _____ Serial Number _____ Delivery date _____

DEALER INSPECTION REPORT

SAFETY

- _____ Farm level
- _____ Wheel bolt tight
- _____ Fasteners tight
- _____ Wiring harness connected
- _____ Check tire pressure

- _____ All decals installed
- _____ Reflectors, SMV clean
- _____ Review operating and safety instructions
- _____ Lubricate machine

I have thoroughly instructed the buyer on the above-described equipment; review included the operator’s manual content, equipment care, adjustments, safe operation, and applicable warranty policy.

Date _____ Dealer’s signature _____

I have received the above equipment and operator’s manual, and I have been thoroughly instructed as to care, adjustments, safe operation, and applicable warranty policy.

Date _____ Owner’s signature _____

Dealer must email a copy of this form to
TILL@PREMIERTILLAGE.COM

TABLE OF CONTENTS: 9-6 PARTS

HITCH ASSEMBLY.....	1
COMPLETE FRAMES	2-12
PICKERS	13-16
CYLINDERS WITH HARDWEAR.....	17
STANDARDS.....	18-19
HUB AND SPINDLE ASSEMBLY.....	20-21
ROCKSHAFT ASSEMBLY	22-25
TIRE AND WHEEL ASSEMBLY	26
COULTER ASSEMBLY	27-29
HYDRAULICS	30

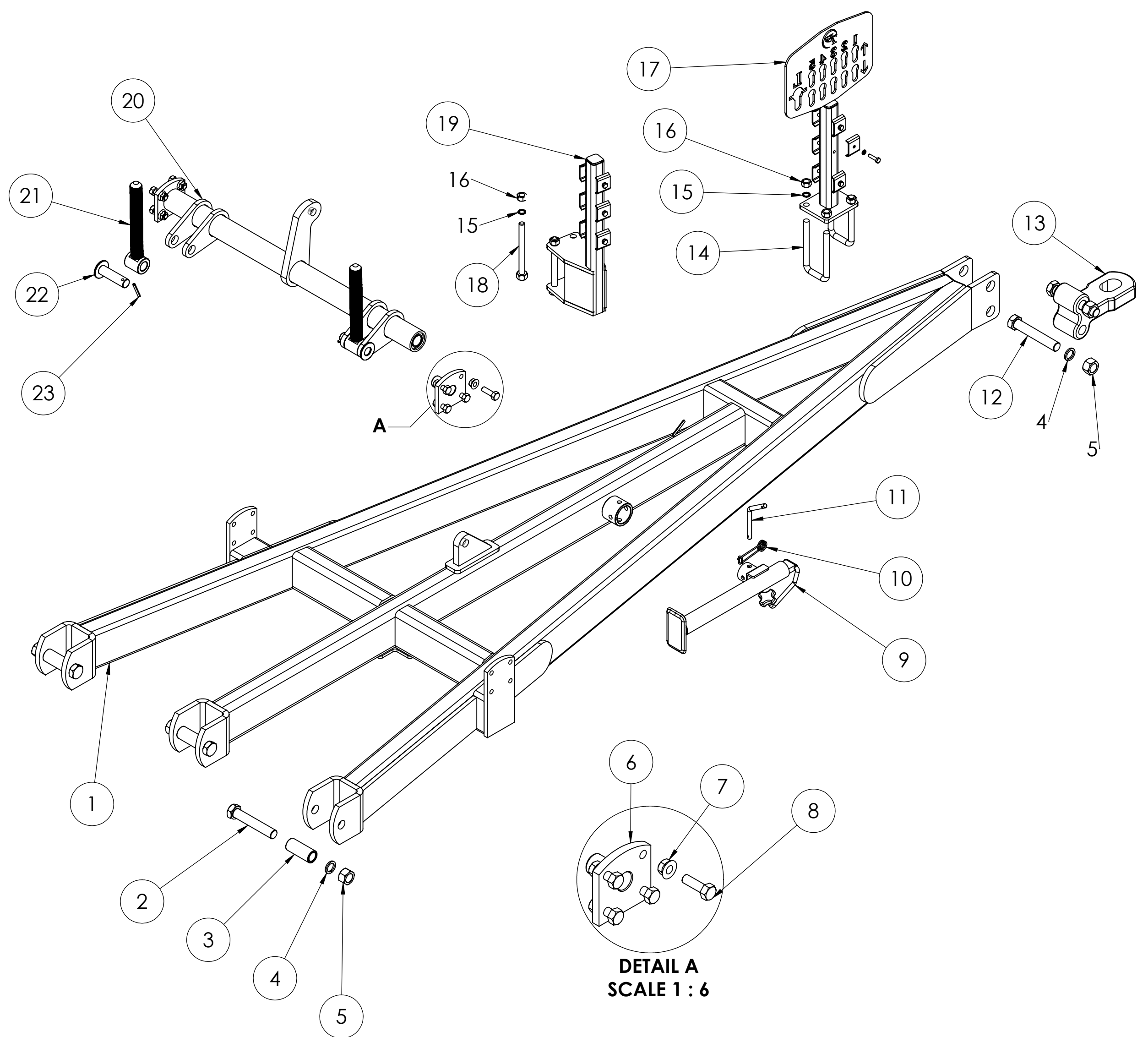
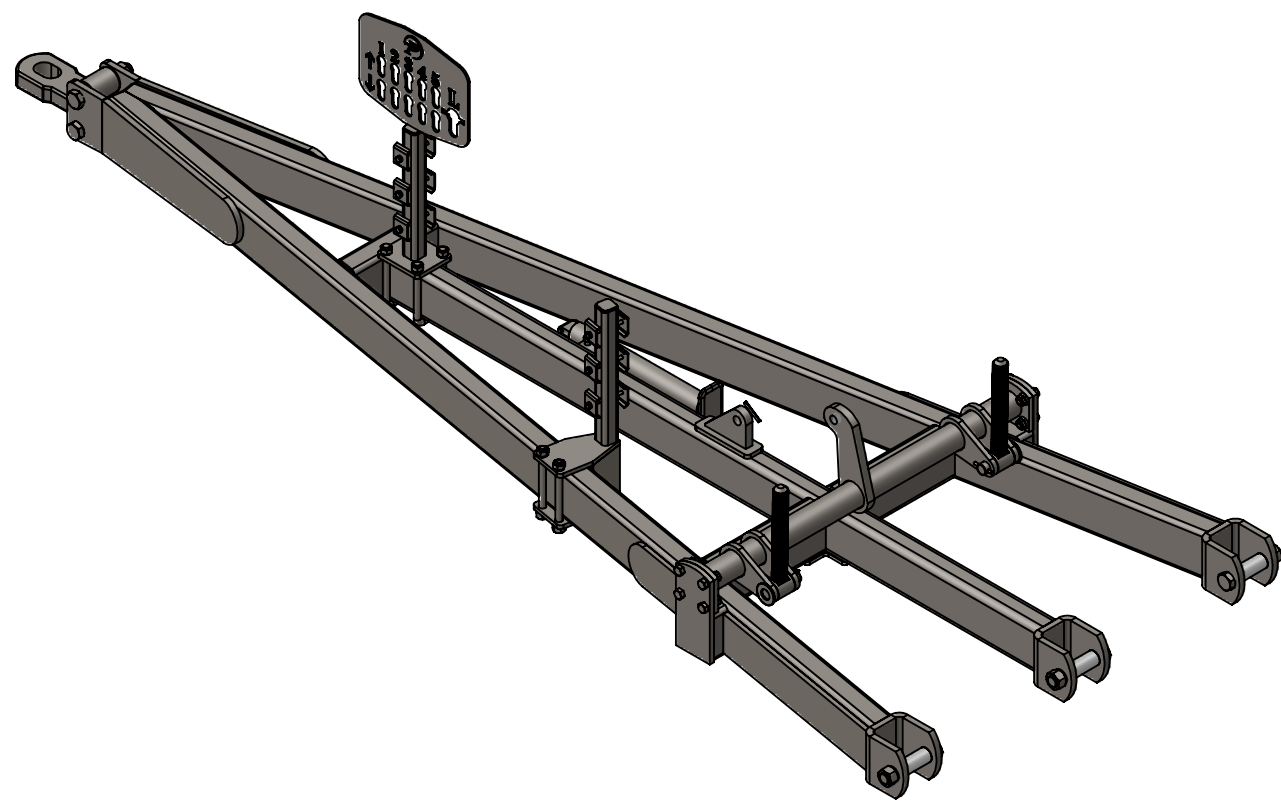

ITEM NO.	PART NUMBER	DESCRIPTION	QTY.
1	MM7000069	9-6' SIII and 11-6' SII HITCH FRAME	1
2	150216	1-1/4" x 7" BOLT	3
3	MM5000488	4" LOOSE HINGE BUSHING	3
4	150157	1-1/4" LOCKWASHER	5
5	150144	1-1/4" NUT	5
6	MM5500052	HITCH ROCKSHAFT BEARING	2
7	150010	5/8" FLANGE NUT	8
8	150111	3/4" x 2" BOLT	8
9	350224	HITCH JACK	1
10	350222	JACK SAFETY PIN	1
11	350223	HITCH JACK PIN	1
12	150214	1-1/4" x 7" BOLT	2
13	300044	HITCH TONGUE	1
14	61-130	3/4"x 3"x 7-3/4" U-BOLT	2
15	150037	3/4" LOCKWASHER	6
16	150038	3/4" NUT	6
17	MM8000007	HOSE STAND	1
18	150137	3/4" x 8" BOLT	2
19	MM7000245	11-6 SECONDARY HOSE STAND	1
20	MM7000250	HEAVY HITCH TRANSPORT ROCKSHAFT	1
21	MM7000050	11-6 HITCH ADJUSTMENT BOLT	2
22	MM7000350	11-6 HITCH ADJUSTMENT PIN	2
23	150006	5/16" x 2-1/2" ROLL PIN	6

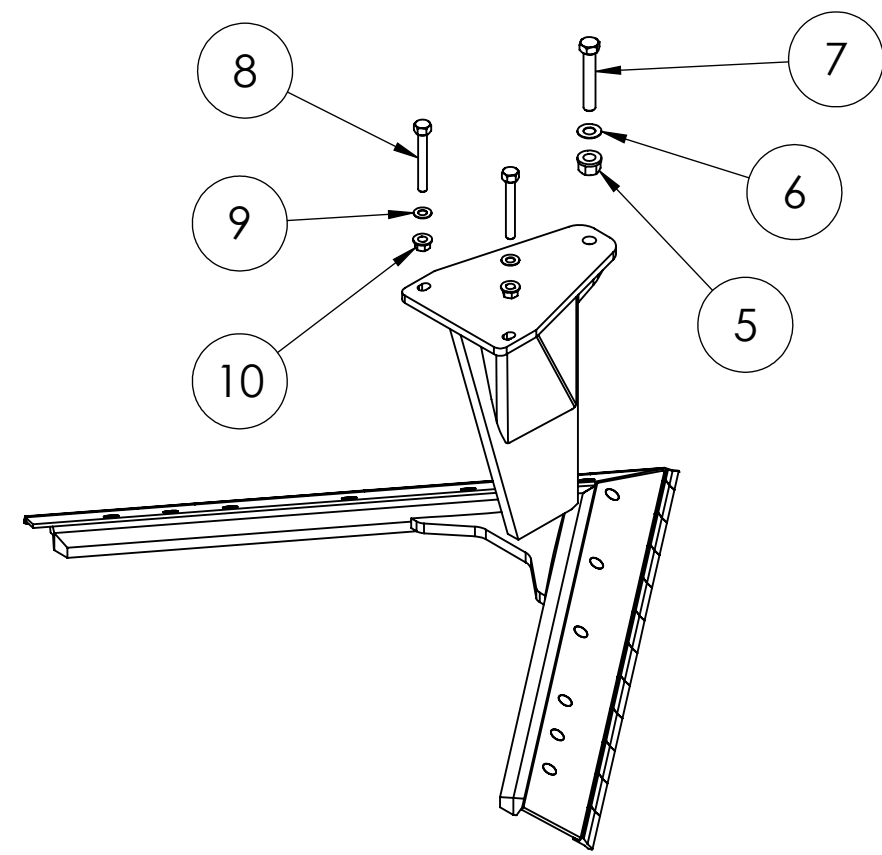

STANDARD
HARDWARE

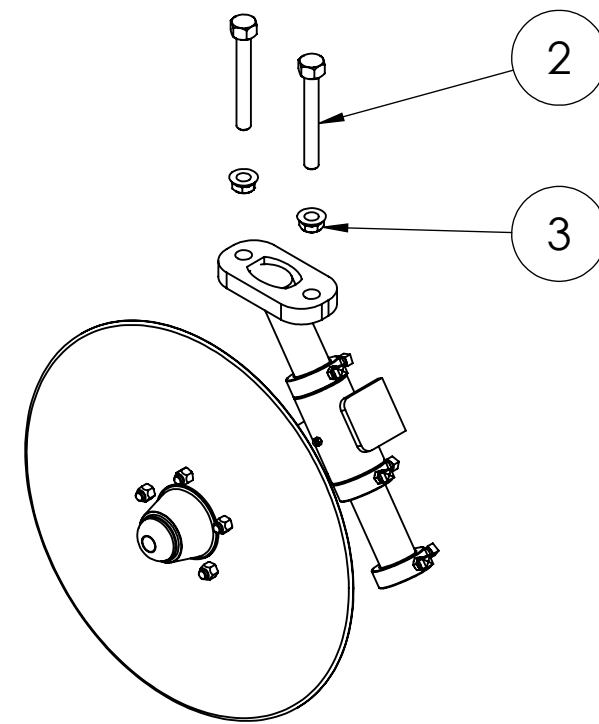

COULTER
HARDWARE

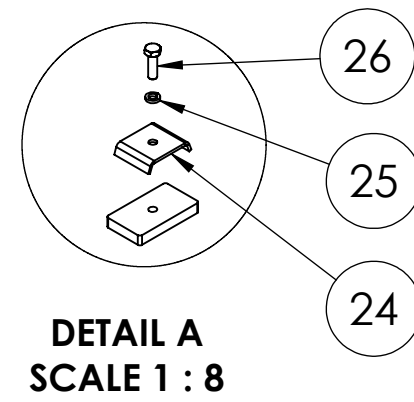
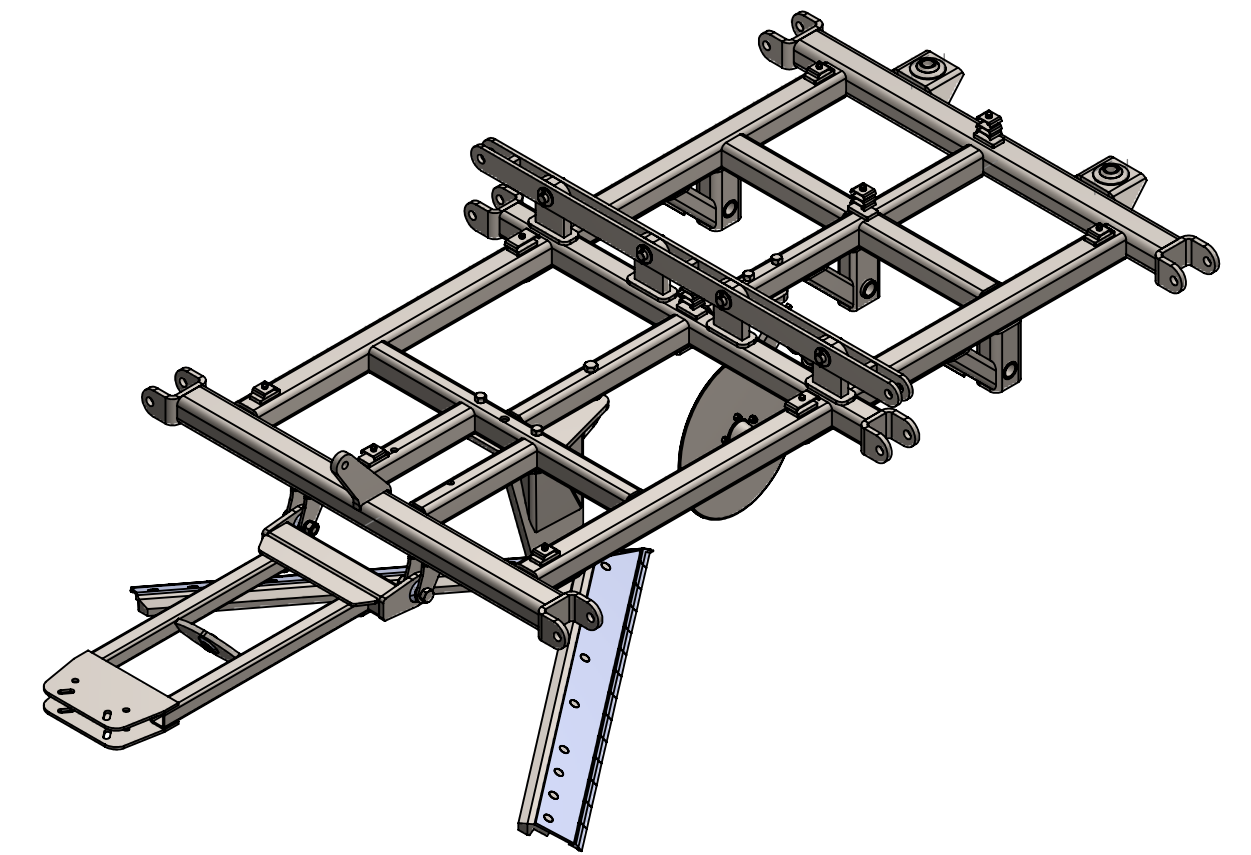

DETAIL A
SCALE 1 : 8

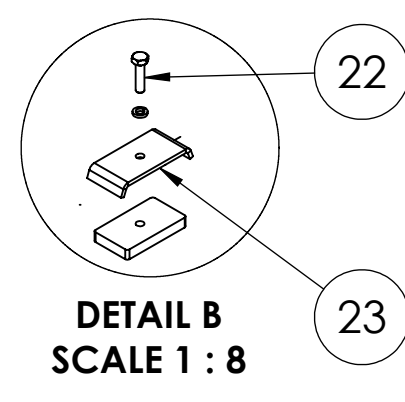

DETAIL B
SCALE 1 : 8

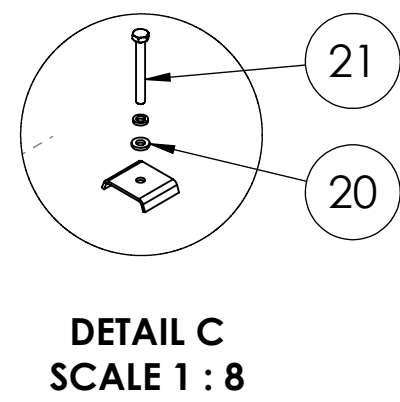

DETAIL C
SCALE 1 : 8

ITEM NO.	PART NUMBER	DESCRIPTION	QTY.
1	MM7000400	11x6 Series II Center Frame	1
2	150016	3/4" x 6" GRADE 2 BOLT	2
3	150021	3/4" FLANGE NUT	2
4	MM9070351	Coulter Assembly	1
5	150059	1" NUT TOP LOCK	1
6	150080	ROUND SHIM	4
7	150052	1" x 6" BOLT	1
8	150019	3/4" x 6" BOLT	2
9	150082	ROUND SHIM	8
10	150093	3/4" TOP LOCK NUT	2
11	MM8000451	SERIES III 6.5 STANDARD ASSY	1
12	MM7000030	PICKER WISHBONE ASSY.	1
13	150002	1-1/8" NUT	2
14	150060	1-1/8" LOCKWASHER	2
15	150158	1-1/8" x 4" BOLT	2
16	MM7000197	FOLD STIFFENER ANCHOR ASSY.	1
17	150172	1-1/4" SAE WASHER	8
18	150006	5/16" x 2-1/2" ROLL PIN	8
19	MM3500024	1-1/4" X 3-1/8" CYLINDER	4
20	150268	3/8" SAE FLAT WASHER	3
21	150075	3/8" x 3-1/4" NF BOLT	3
22	150333	3/8" x 1-1/2" NF BOLT	2
23	MM7000038	HYDRAULIC HOSE CLAMP WIDE	2
24	MM7000041	HOSE CLAMP NARROW	14
25	150077	3/8" LOCKWASHER	10
26	150332	3/8" x 1-1/4" NF BOLT	5

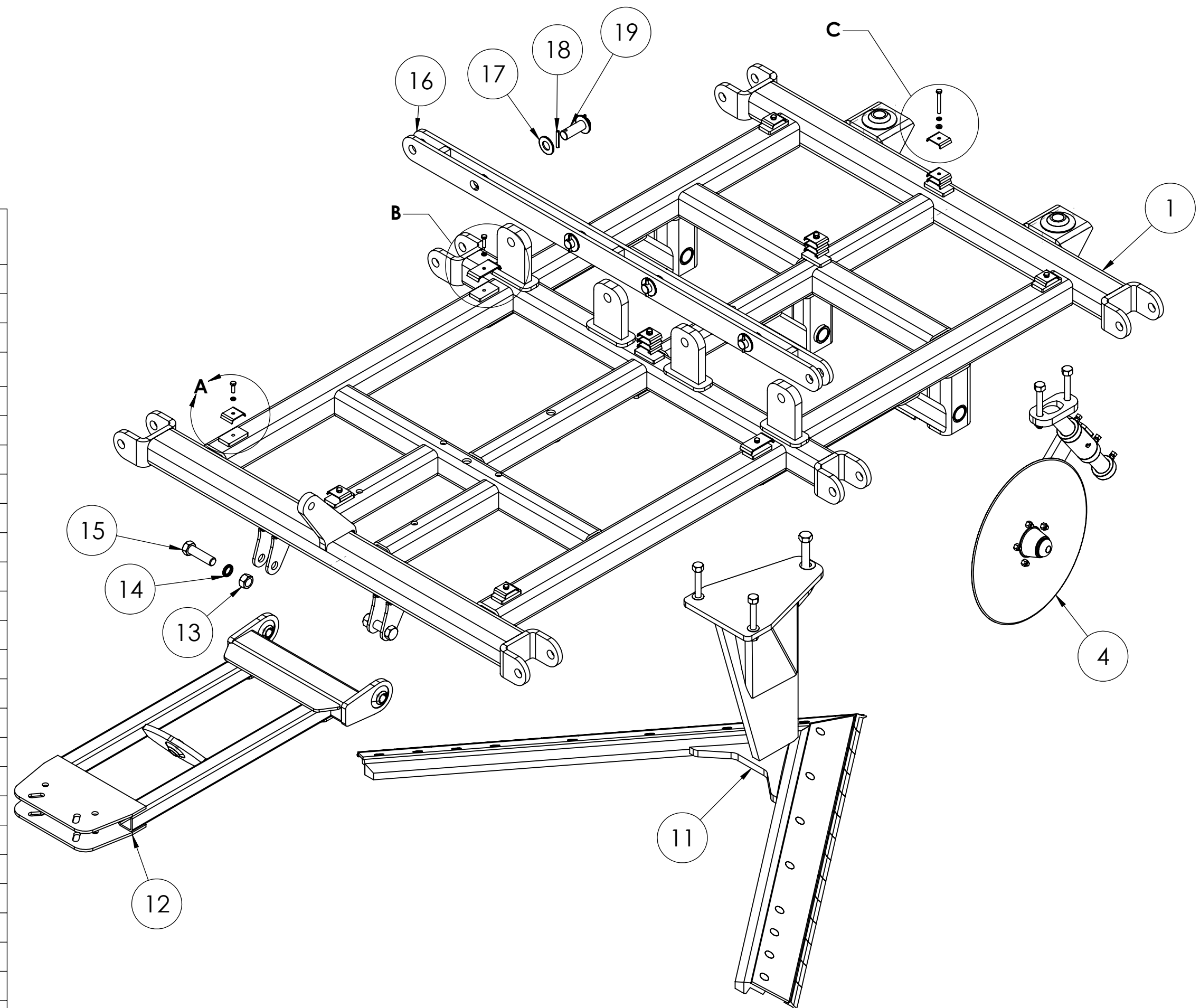

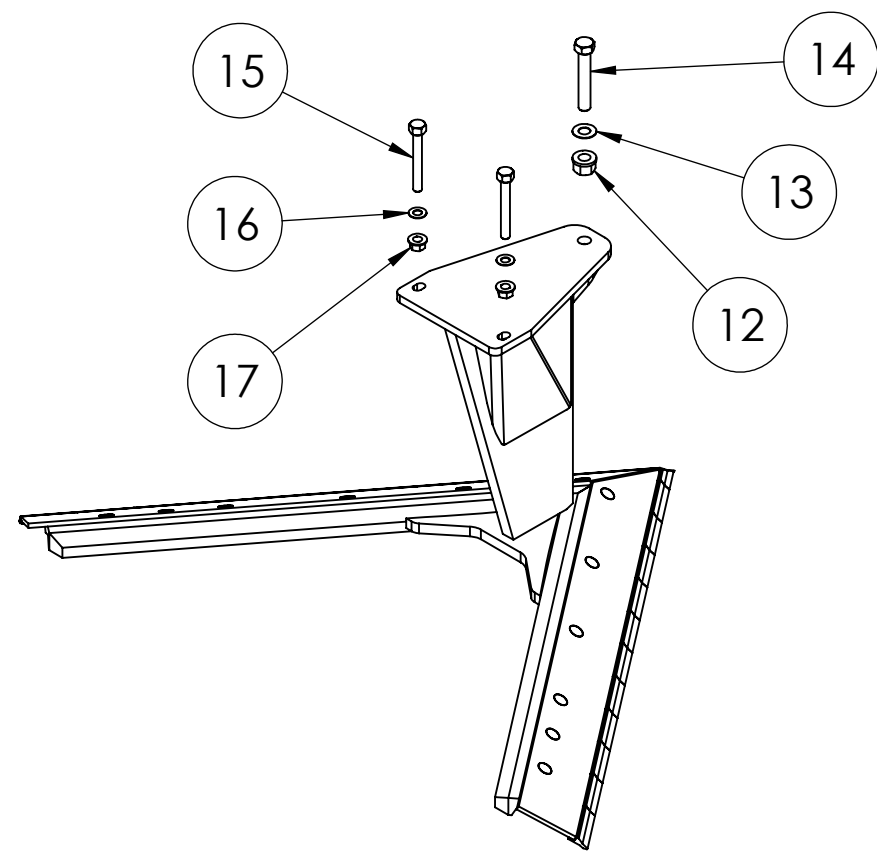

STANDARD
HARDWARE

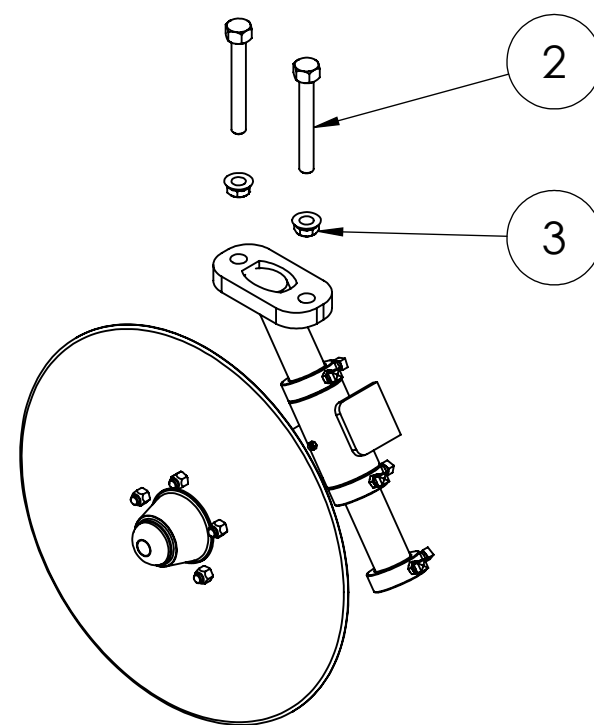

COULTER
HARDWARE

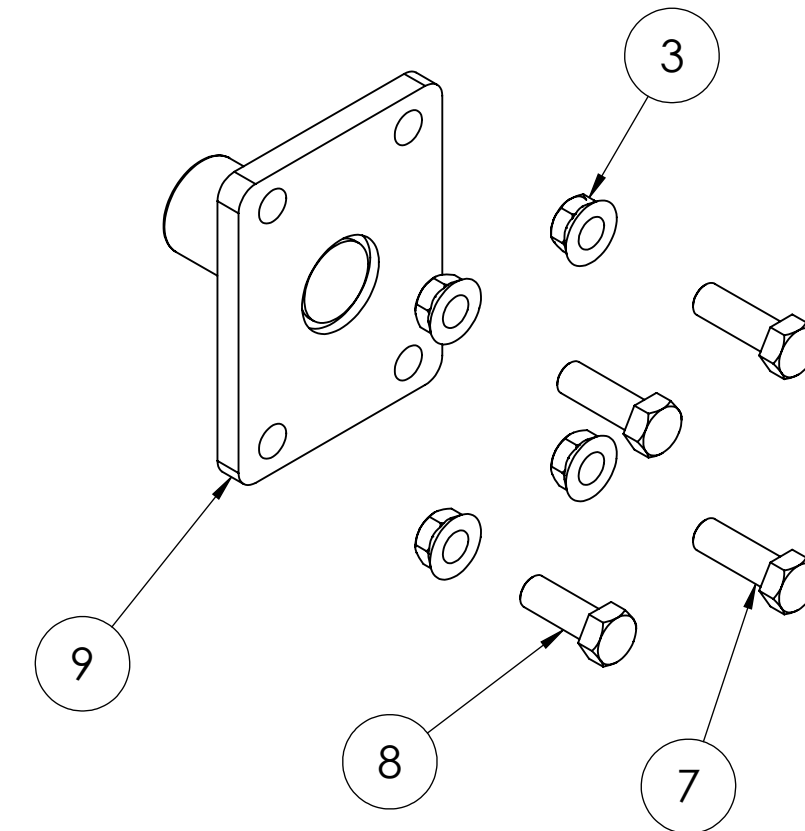

ROCKSHAFT STUDPLATE
HARDWARE

ITEM NO.	PART NUMBER	DESCRIPTION	QTY.
1	MM7000401	9x6 Series III Right Center Frame	1
2	150016	3/4" x 6" BOLT	2
3	150021	3/4" FLANGE NUT	31
4	MM9000051	SIII Coultter Assembly	1
5	320033	22-1/2" COULTER BLADE	1
6	MM8000503	11-6 LEFT DUAL ROCKSHAFT ASSY.	1
7	150017	3/4" x 2-1/4" BOLT	18
8	150057	3/4" x 2" BOLT	6
9	MM7000019	ROCKSHAFT BEARING STUD PLATE	6
10	MM8000201	Right Rockshaft Assembly	1
11	MM8000450	6' STANDARD SERIES III	1
12	150059	1" NUT TOP LOCK	1
13	150080	ROUND SHIM	4
14	150052	1" x 6" BOLT	1
15	150019	3/4" x 6" BOLT	2
16	150082	ROUND SHIM	8
17	150093	3/4" TOP LOCK NUT	1
18	MM7000030	PICKER WISHBONE ASSY.	1
19	150002	1-1/8" NUT	2
20	150060	1-1/8" LOCKWASHER	2
21	150158	1-1/8" x 4" BOLT	2
22	150172	1-1/4" SAE WASHER	8
23	MM3500024	1-1/4" X 3-1/8" CYLINDER	4
24	150006	5/16" x 2-1/2" ROLL PIN	8
25	150156	1-1/2" JAM NUT	9
26	MM1500001	Wedge Lock Washer	3
27	MM7000269	DEPTH ADJ. ANCHOR BOLT	3
28	MM8000200	LEFT ROCKSHAFT ASSY. KIT	1
29	MM7000041	HOSE CLAMP NARROW	12
30	150077	3/8" LOCKWASHER	12
31	150332	3/8" x 1-1/4" NF BOLT	12
32	150085	1" x 3-1/2" BOLT	4
33	150033	1" LOCKWASHER	4
34	150036	1" JAM NUT	4

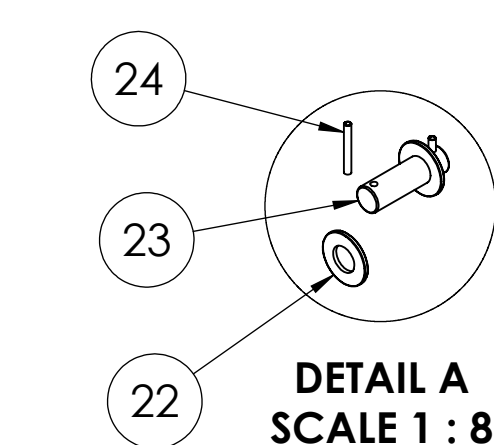
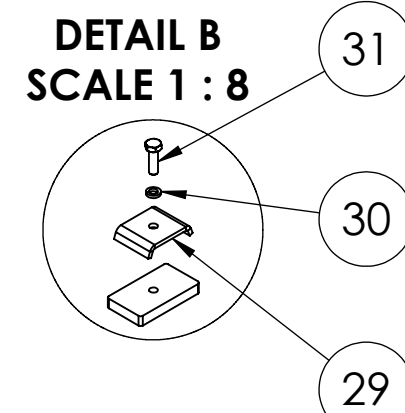

DETAIL C
SCALE 1 : 8

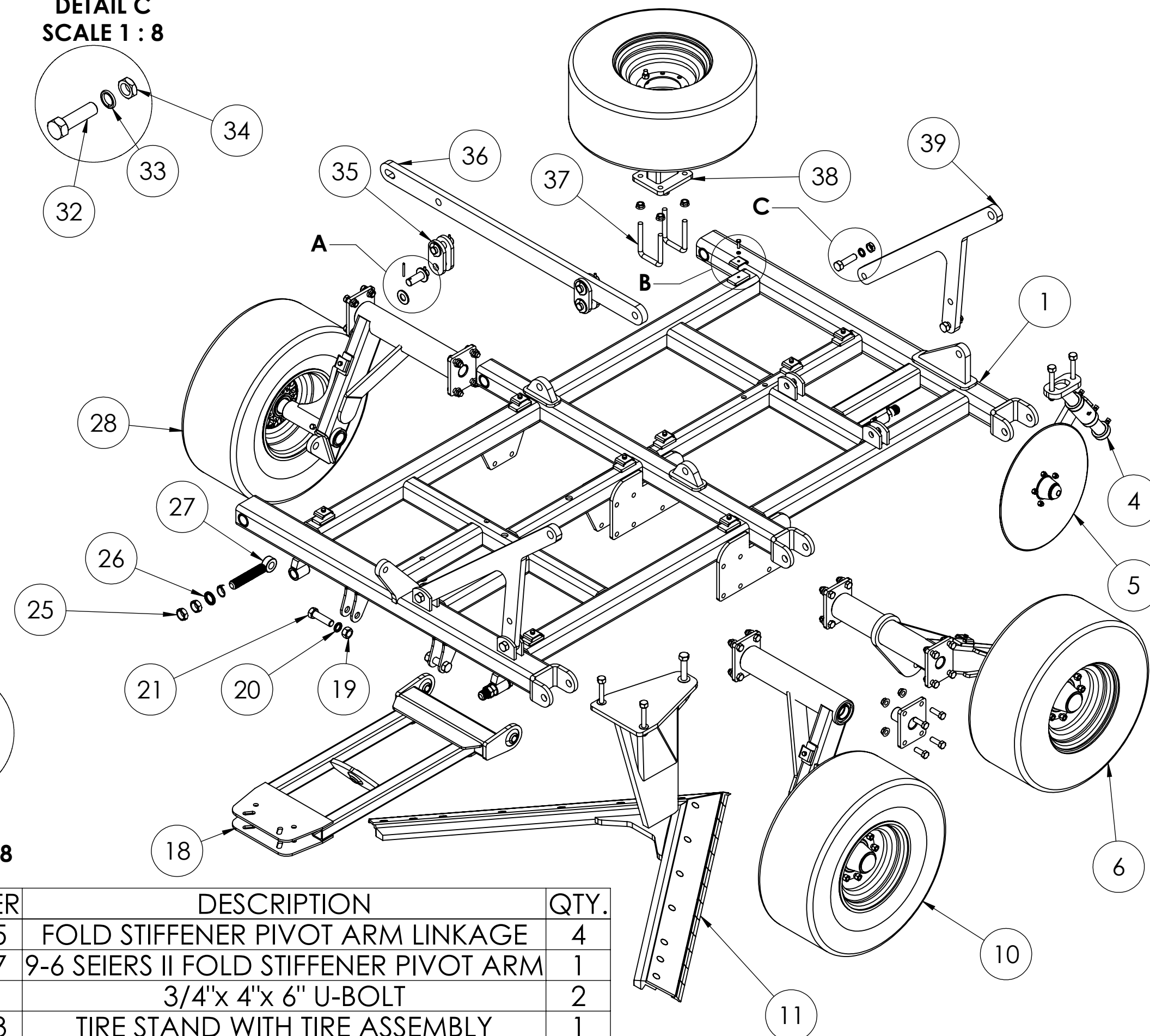

ITEM NO.	PART NUMBER	DESCRIPTION	QTY.
35	MM5000055	FOLD STIFFENER PIVOT ARM LINKAGE	4
36	MM5000077	9-6 SEIERS II FOLD STIFFENER PIVOT ARM	1
37	61-125	3/4"x 4"x 6" U-BOLT	2
38	MM8000013	TIRE STAND WITH TIRE ASSEMBLY	1
39	MM7000280	9x6 Series III Inside Lock up arm	2

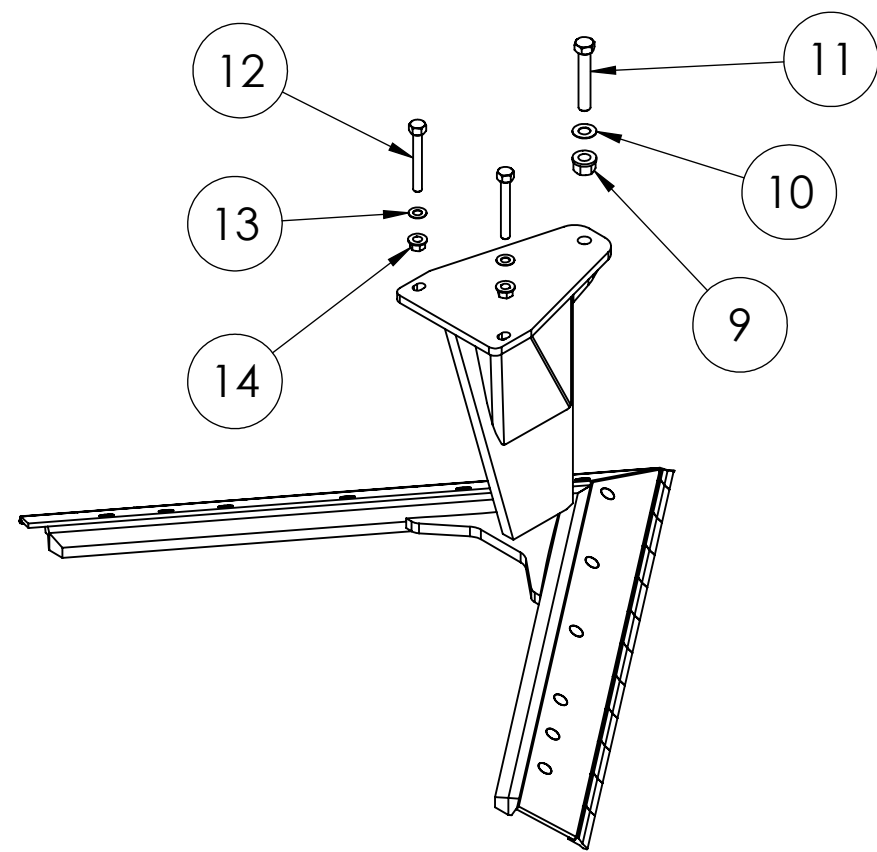

STANDARD
HARDWARE

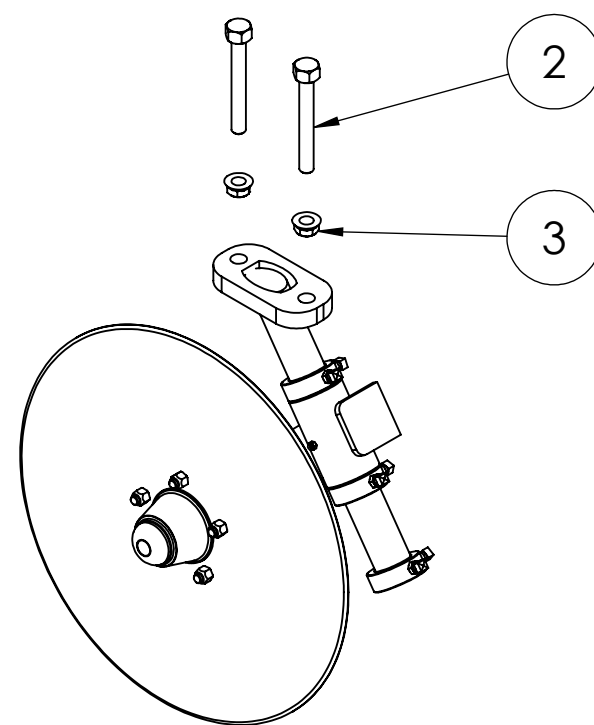

COULTER
HARDWARE

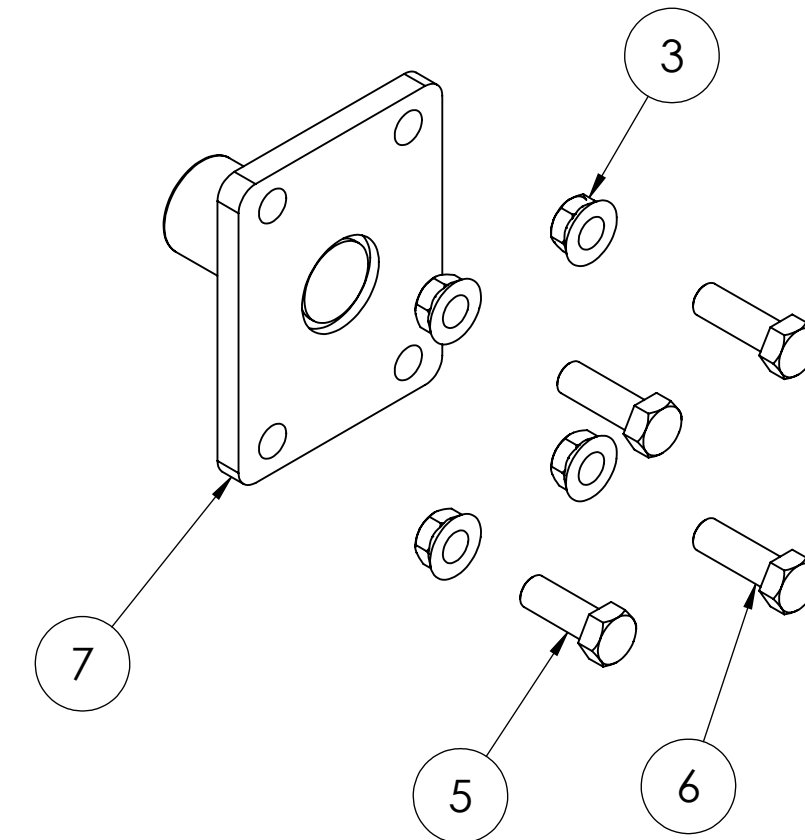

ROCKSHAFT STUDPLATE
HARDWARE

ITEM NO.	PART NUMBER	DESCRIPTION	QTY.
1	MM7000402	9x6 Series III Left Center Frame	1
2	150016	3/4" x 6" BOLT	2
3	150021	3/4" FLANGE NUT	26
4	MM9070351	Coultter Assembly	1
5	150057	3/4" x 2" BOLT	3
6	150017	3/4" x 2-1/4" BOLT	21
7	MM7000019	ROCKSHAFT BEARING STUD PLATE	6
8	MM8000201	Right Rockshaft	1
9	150059	1" NUT TOP LOCK	1
10	150080	ROUND SHIM	4
11	150052	1" x 6" BOLT	1
12	150019	3/4" x 6" BOLT	2
13	150082	ROUND SHIM	8
14	150093	3/4" TOP LOCK NUT	2
15	MM8000450	6' STANDARD SERIES III	1
16	MM7000030	PICKER WISHBONE ASSY.	1
17	150002	1-1/8" NUT	2
18	150060	1-1/8" LOCKWASHER	2
19	150158	1-1/8" x 4" BOLT	2
20	150156	1-1/2" JAM NUT	9
21	MM1500001	Wedge Lock Washer	1
22	MM7000269	DEPTH ADJ. ANCHOR BOLT	3
23	MM7000041	HOSE CLAMP NARROW	12
24	150077	3/8" LOCKWASHER	12
25	150332	3/8" x 1-1/4" NF BOLT	12
26	MM8000200	LEFT ROCKSHAFT ASSY. KIT	1
27	MM8000502	11-6 RIGHT ROCKSHAFT ASSEMBLY	1
28	150172	1-1/4" SAE WASHER	8
29	150006	5/16" x 2-1/2" ROLL PIN	8
30	MM5000077	FOLD STIFFENER PIVOT ARM	1
31	MM3500024	1-1/4" X 3-1/8" CYLINDER	4
32	MM5000055	FOLD STIFFENER PIVOT ARM LINKAGE	4
33	150085	1" x 3-1/2" BOLT	4

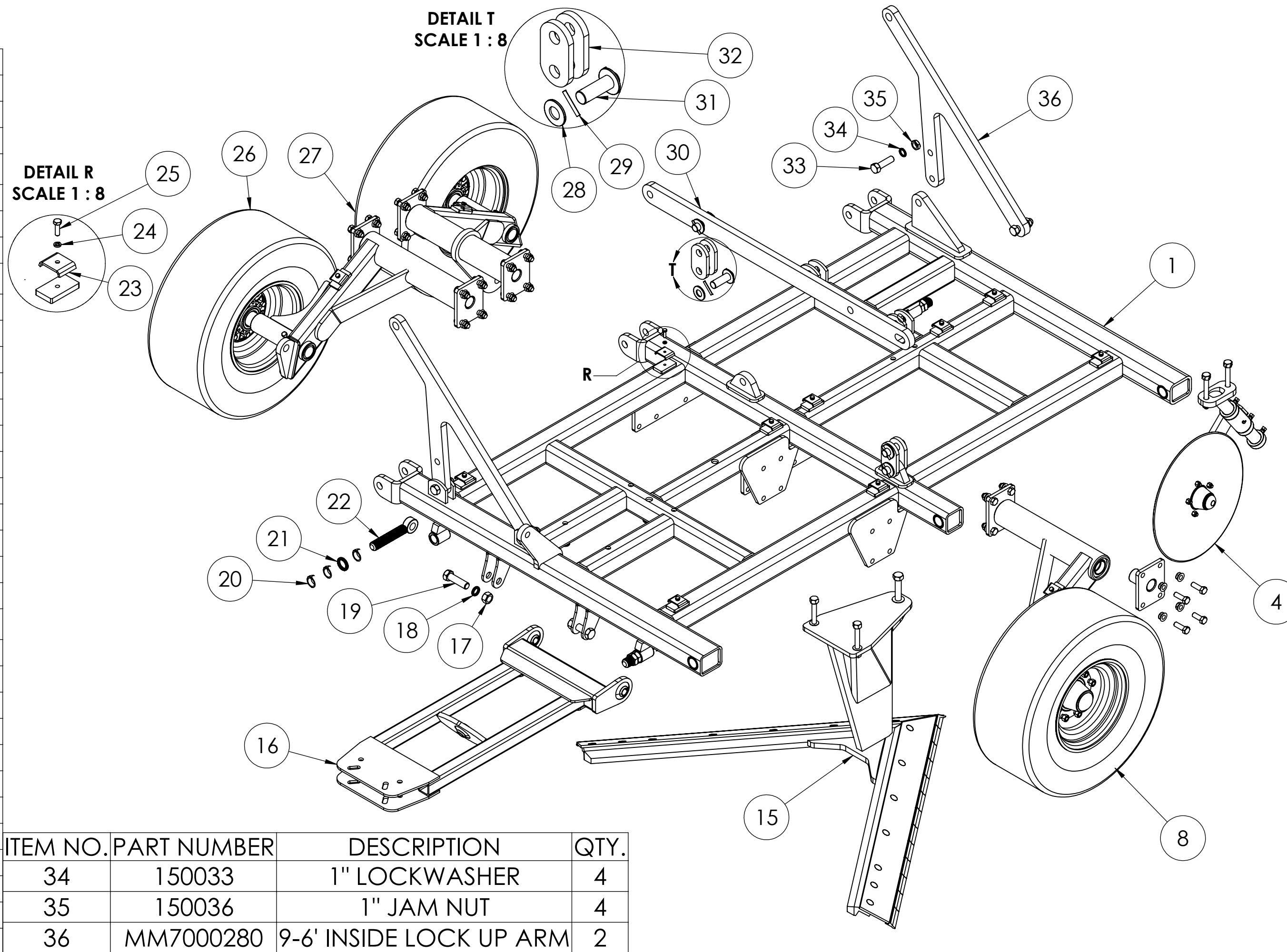

ITEM NO.	PART NUMBER	DESCRIPTION	QTY.
34	150033	1" LOCKWASHER	4
35	150036	1" JAM NUT	4
36	MM7000280	9-6' INSIDE LOCK UP ARM	2

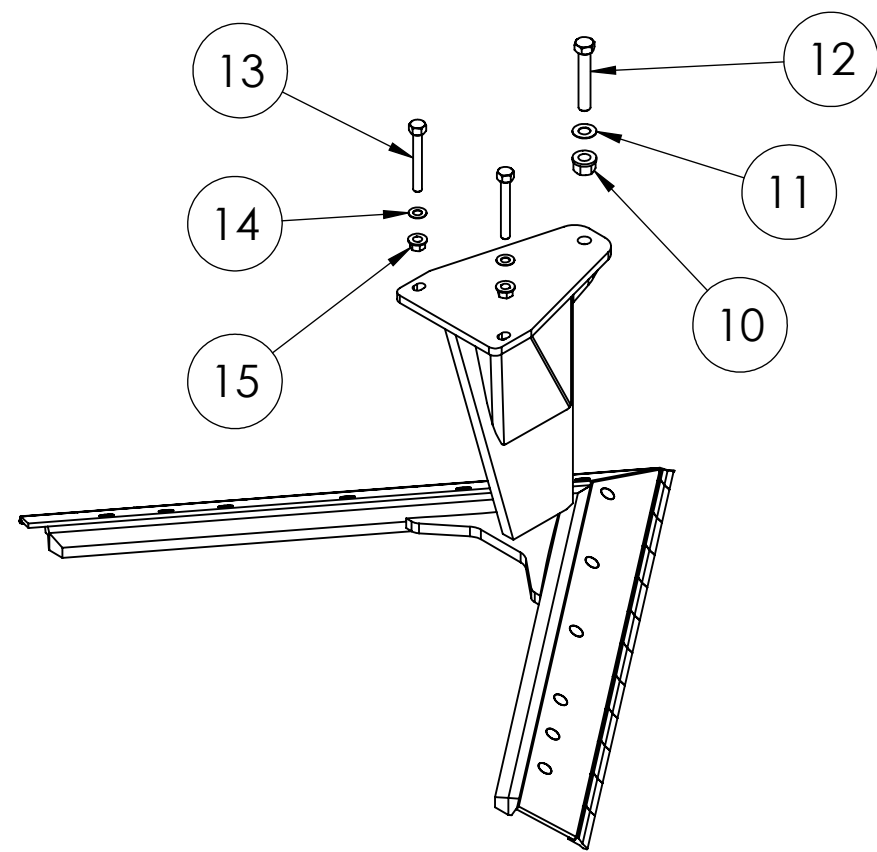

STANDARD
HARDWARE

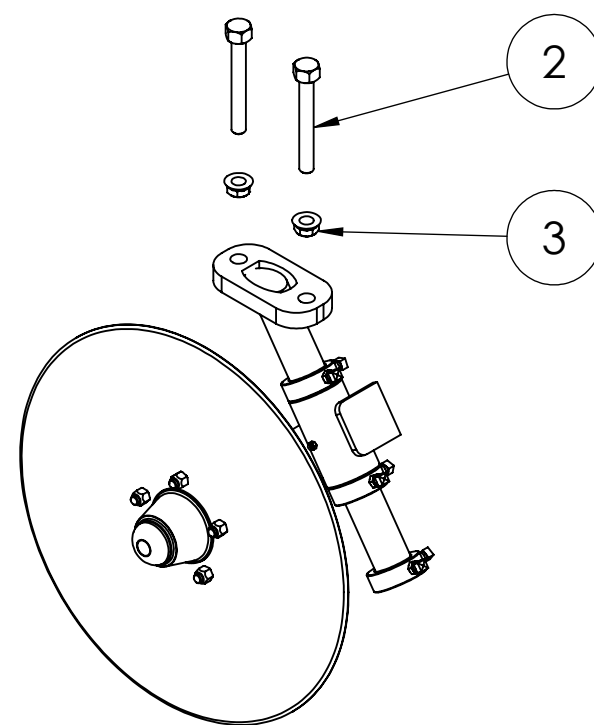

COULTER
HARDWARE

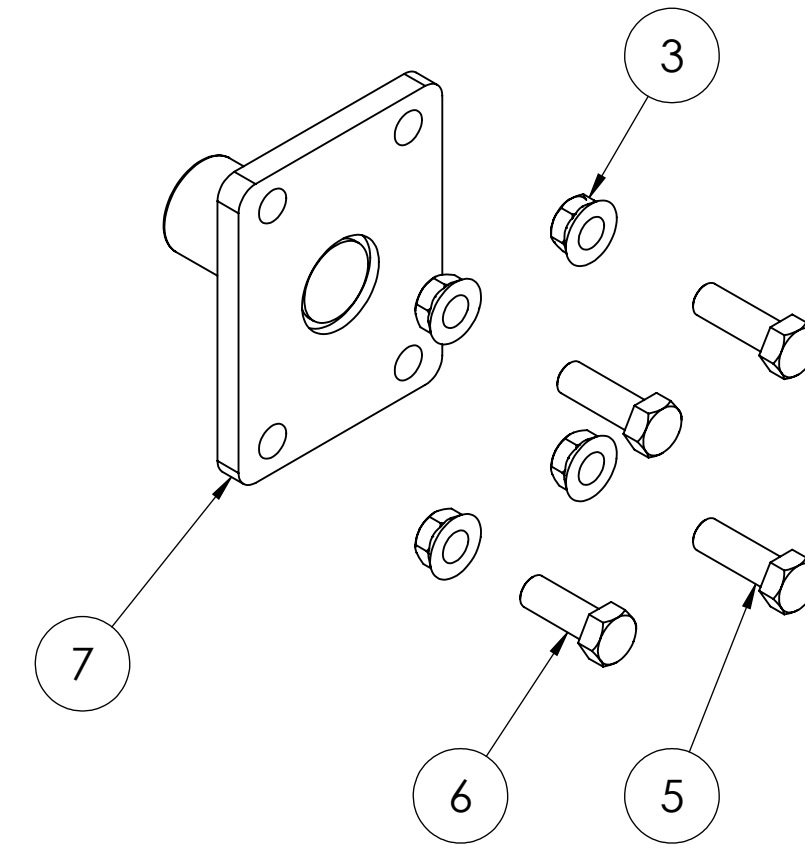

ROCKSHAFT STUDPLATE
HARDWARE

ITEM NO.	PART NUMBER	DESCRIPTION	QTY.
1	MM7000403	9x6 Series III Right Center Insert	1
2	150016	3/4" x 6" BOLT	2
3	150021	3/4" FLANGE NUT	10
4	MM9070351	Coulter Assembly	1
5	150017	3/4" x 2-1/4" BOLT	7
6	150057	3/4" x 2" BOLT	1
7	MM7000019	ROCKSHAFT BEARING STUD PLATE	2
8	MM8000201	Right Rockshaft	1
9	MM5000575	STUBBLE RELEASE KNIFE	1
10	150059	1" NUT TOP LOCK	1
11	150080	ROUND SHIM	4
12	150052	1" x 6" BOLT	1
13	150019	3/4" x 6" BOLT	2
14	150082	ROUND SHIM	8
15	150093	3/4" TOP LOCK NUT	2
16	MM8000451	SERIES III 6.5 STANDARD ASSY	1
17	MM7000269	DEPTH ADJ. ANCHOR BOLT	1
18	MM1500001	Wedge Lock Washer	1
19	150156	1-1/2" JAM NUT	3
20	150002	1-1/8" NUT	2
21	150060	1-1/8" LOCKWASHER	2
22	150158	1-1/8" x 4" BOLT	2
23	MM7000030	PICKER WISHBONE ASSY.	1
24	MM7000041	HOSE CLAMP NARROW	6
25	150077	3/8" LOCKWASHER	6
26	150332	3/8" x 1-1/4" NF BOLT	6
27	MM5000037	9-6' INNER FOLD FLOP TAB	2
28	151599	1-1/2" SAE WASHER	12
29	150006	5/16" x 2-1/2" ROLL PIN	12
30	MM3500023	1-1/2" x 3-1/8" PIN	6
31	MM5000080	9-6 SERIES II FOLD PENDULUM	2
32	150085	1" x 3-1/2" BOLT	4

DETAIL B
SCALE 1 : 8

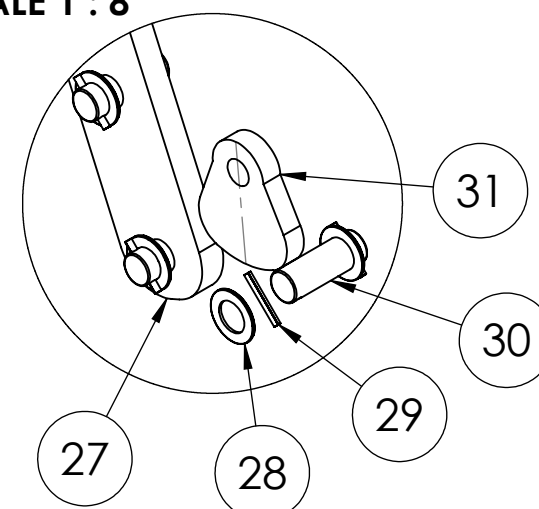

DETAIL A
SCALE 1 : 8

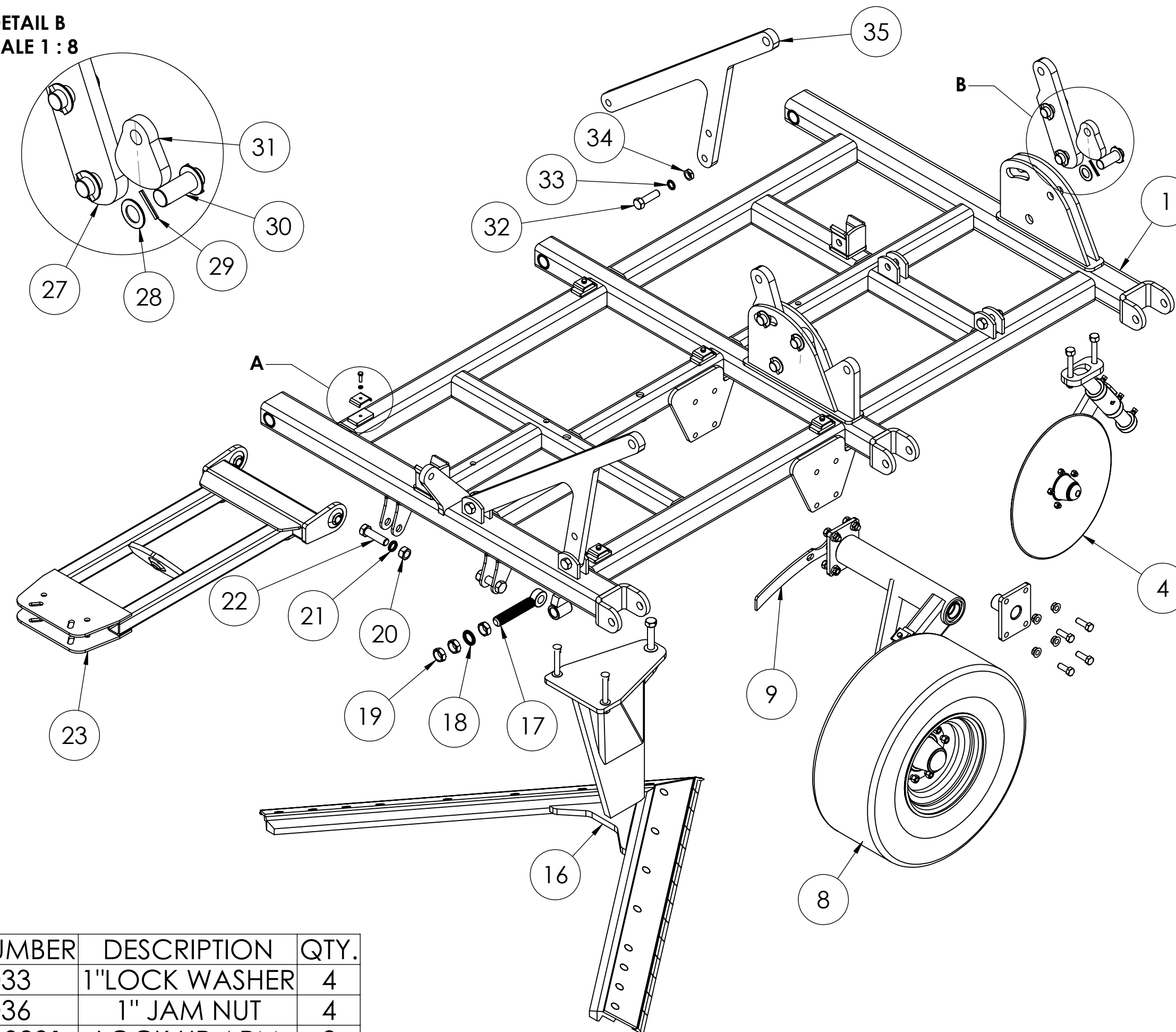
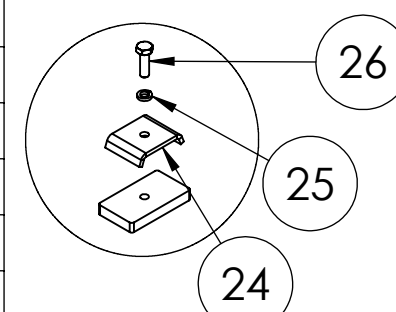

ITEM NO.	PART NUMBER	DESCRIPTION	QTY.
33	150033	1" LOCK WASHER	4
34	150036	1" JAM NUT	4
35	MM7000281	LOCK UP ARM	2

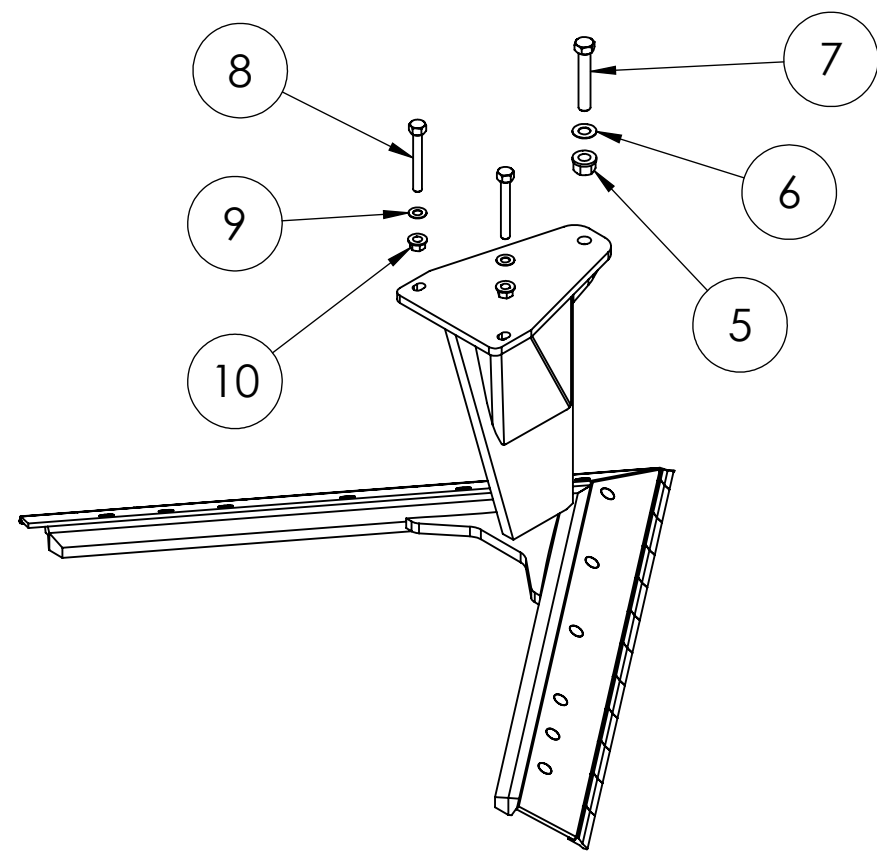

STANDARD
HARDWARE

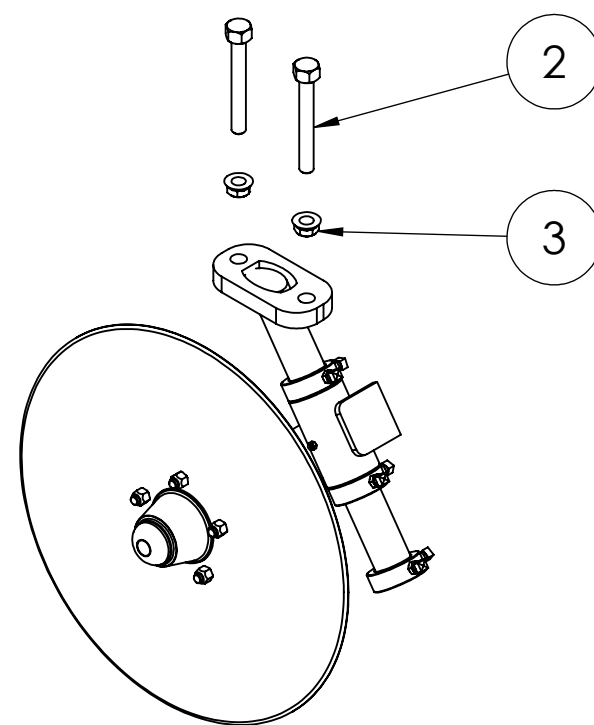

COULTER
HARDWARE

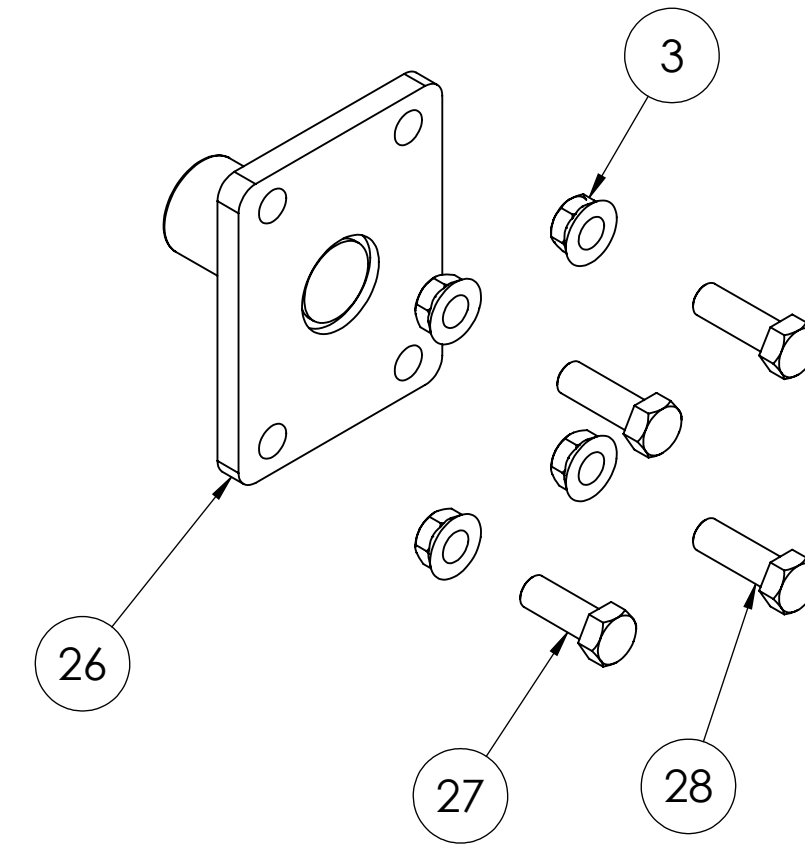

ROCKSHAFT STUDPLATE
HARDWARE

ITEM NO.	PART NUMBER	DESCRIPTION	QTY.
1	MM7000404	9x6 Series III Left Center Insert	1
2	150016	3/4" x 6" BOLT	2
3	150021	3/4" FLANGE NUT	10
4	MM9070351	Coultter Assembly	1
5	150059	1" NUT TOP LOCK	1
6	150080	ROUND SHIM	4
7	150052	1" x 6" BOLT	1
8	150019	3/4" x 6" BOLT	2
9	150082	ROUND SHIM	8
10	150093	3/4" TOP LOCK NUT	2
11	MM8000451	SERIES III 6.5 STANDARD ASSY	1
12	MM7000030	PICKER WISHBONE ASSY.	1
13	150002	1-1/8" NUT	2
14	150060	1-1/8" LOCKWASHER	2
15	150158	1-1/8" x 4" BOLT	2
16	MM7000269	DEPTH ADJ. ANCHOR BOLT	1
17	MM1500001	Wedge Lock Washer	1
18	150156	1-1/2" JAM NUT	3
19	MM7000041	HOSE CLAMP NARROW	6
20	150077	3/8" LOCKWASHER	6
21	150332	3/8" x 1-1/4" NF BOLT	6
22	150085	1" x 3-1/2" BOLT	4
23	150033	1" LOCKWASHER	4
24	150036	1" JAM NUT	4
25	MM7000281	9-6' SIII LEFT CENTER INSERT LOCKUP	2
26	MM7000019	ROCKSHAFT BEARING STUD PLATE	2
27	150057	3/4" x 2" BOLT	1
28	150017	3/4" x 2-1/4" BOLT	7
29	MM8000200	LEFT ROCKSHAFT ASSY. KIT	1
30	MM5000575	STUBBLE RELEASE KNIFE	1
31	151599	1-1/2" SAE WASHER	12
32	150006	5/16" x 2-1/2" ROLL PIN	12
33	MM3500023	1-1/2" x 3-1/8" PIN	6
34	MM5000080	9-6 SERIES II FOLD PENDULUM	2
35	MM5000037	9-6' INNER FOLD FLOP TAB	2

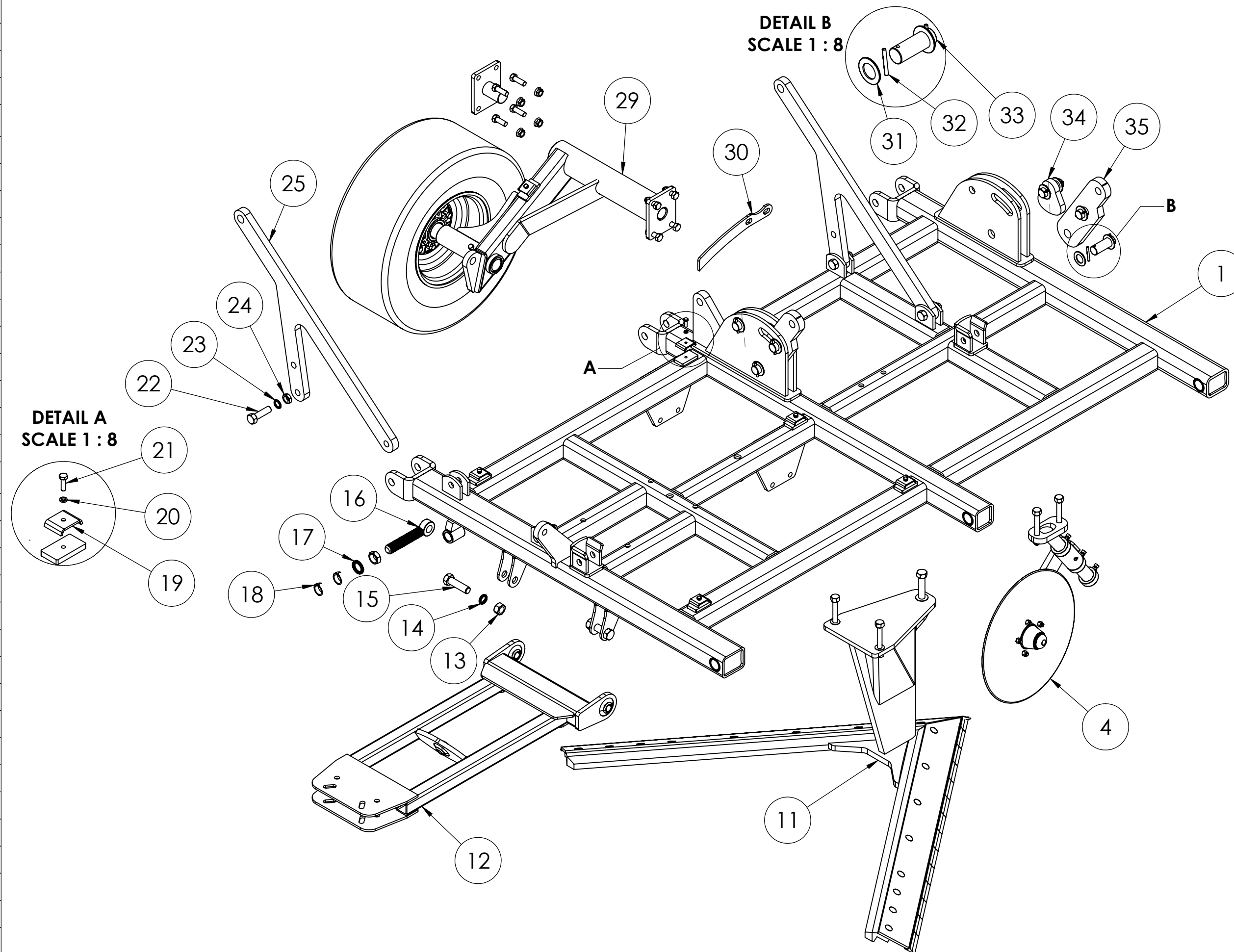

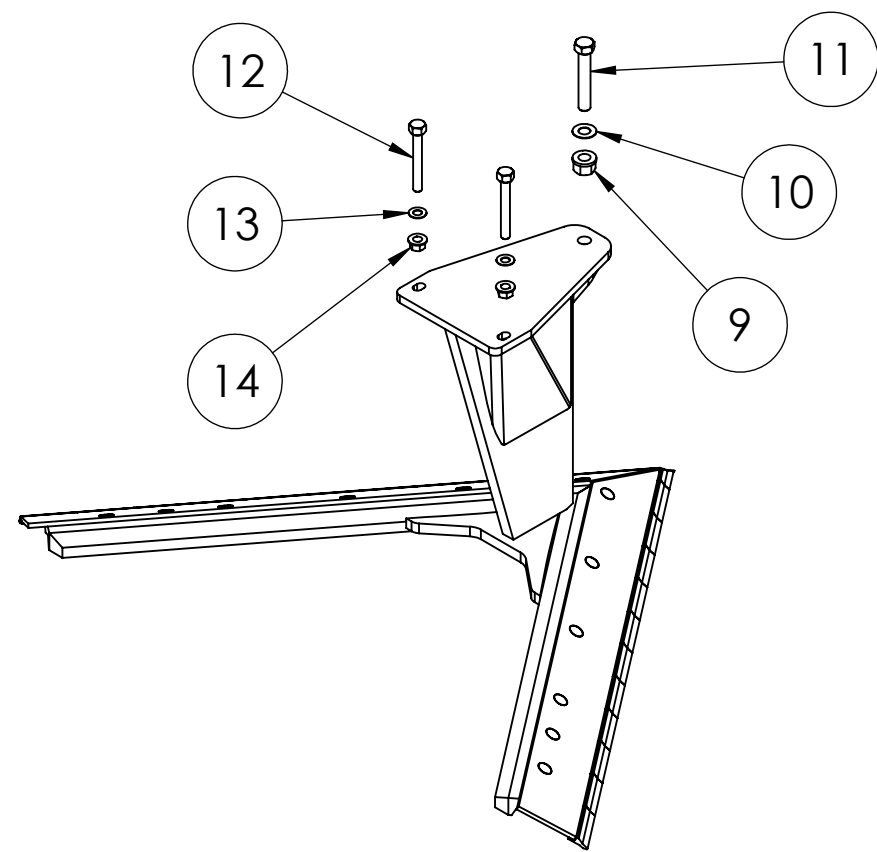

STANDARD
HARDWARE

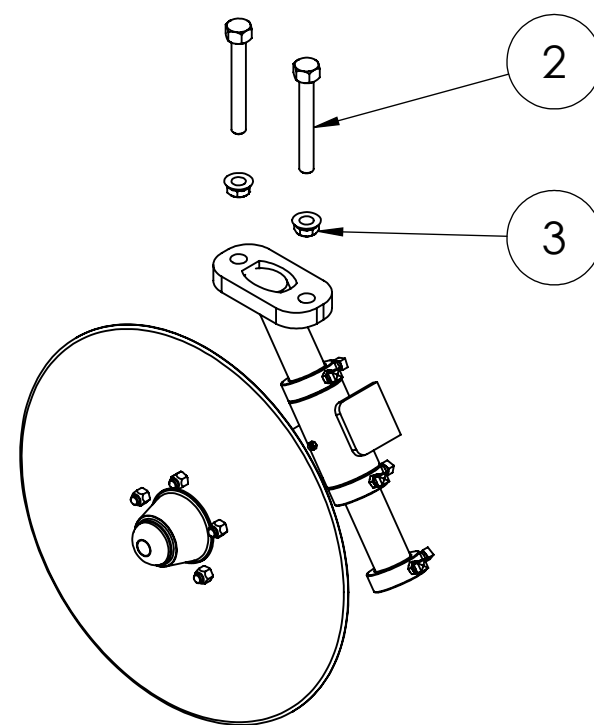

COULTER
HARDWARE

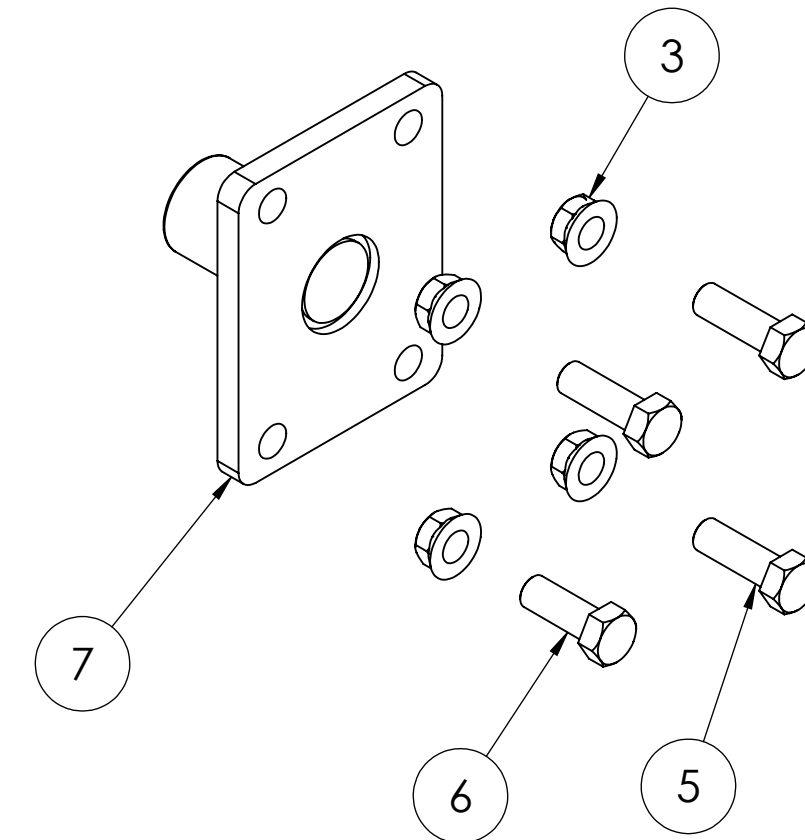

ROCKSHAFT STUDPLATE
HARDWARE

ITEM NO.	PART NUMBER	DESCRIPTION	QTY.
1	MM7000405	9x6 Series III right insert wing	1
2	150016	3/4" x 6" BOLT	2
3	150021	3/4" FLANGE NUT	10
4	MM9070351	Coultter Assembly	1
5	150017	3/4" x 2-1/4" BOLT	7
6	150057	3/4" x 2" BOLT	1
7	MM7000019	ROCKSHAFT BEARING STUD PLATE	2
8	MM8000201	Right Rockshaft ASSY.	1
9	150059	1" NUT TOP LOCK	1
10	150080	ROUND SHIM	4
11	150052	1" x 6" BOLT	1
12	150019	3/4" x 6" BOLT	2
13	150082	ROUND SHIM	8
14	150093	3/4" TOP LOCK NUT	2
15	MM8000450	6' STANDARD SERIES III	1
16	MM7000269	DEPTH ADJ. ANCHOR BOLT	1
17	MM1500001	Wedge Lock Washer	1
18	150156	1-1/2" JAM NUT	3
19	150158	1-1/8" x 4" BOLT	2
20	150060	1-1/8" LOCKWASHER	2
21	150002	1-1/8" NUT	2
22	MM7000030	PICKER WISHBONE ASSY.	1
23	MM7000041	HOSE CLAMP NARROW	6
24	150077	3/8" LOCKWASHER	6
25	150332	3/8" x 1-1/4" NF BOLT	6
26	150036	1" JAM NUT	2
27	150033	1" LOCKWASHER	2
28	150085	1" x 3-1/2" BOLT	2
29	MM7000282	LOCKUP ARM	1

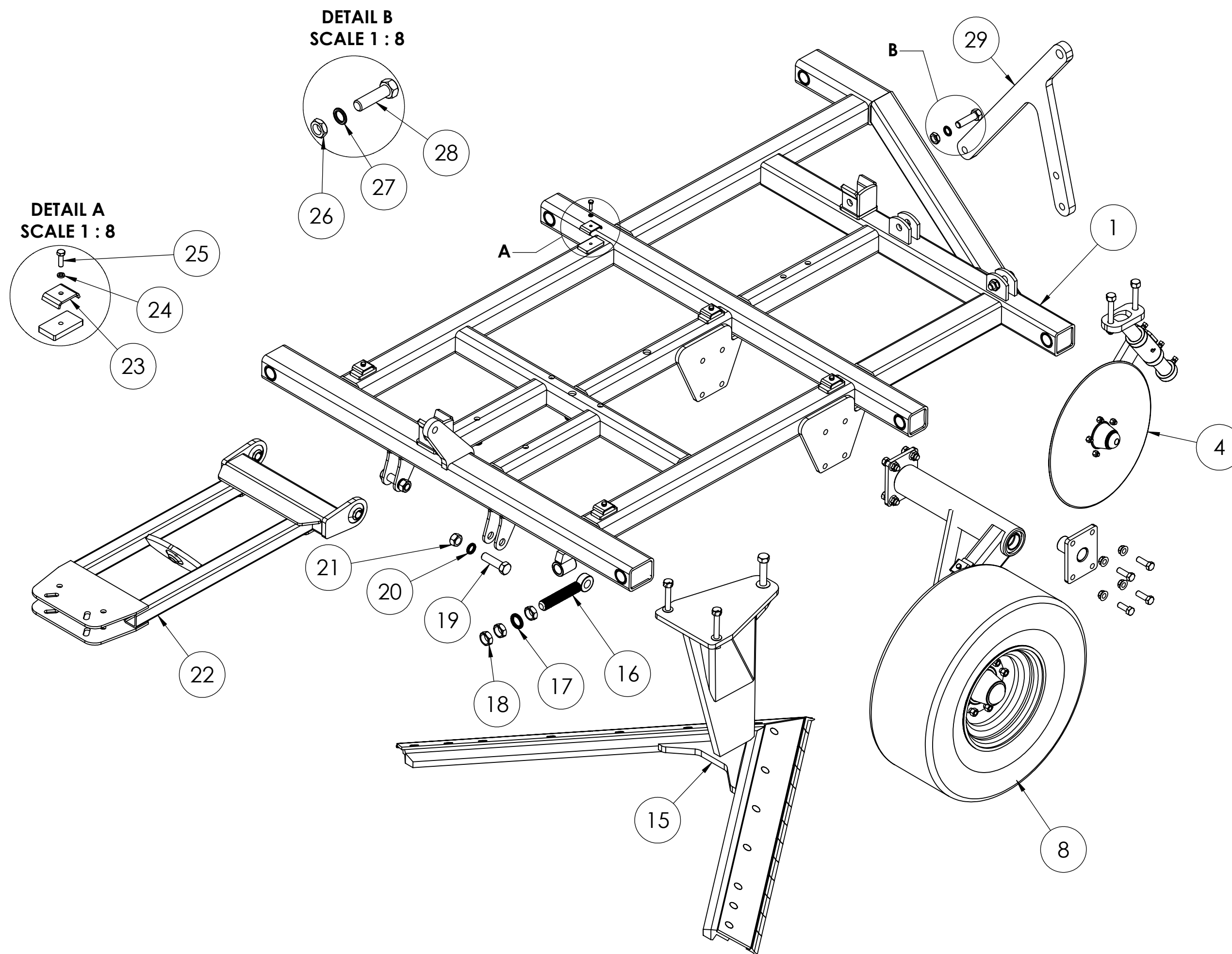

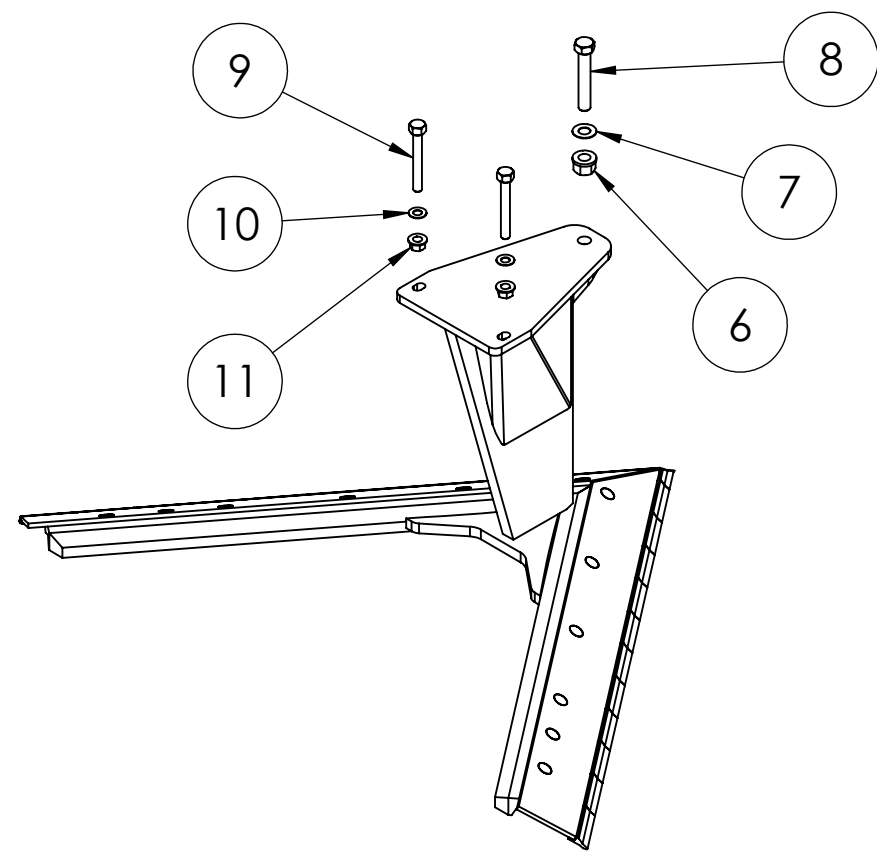

STANDARD
HARDWARE

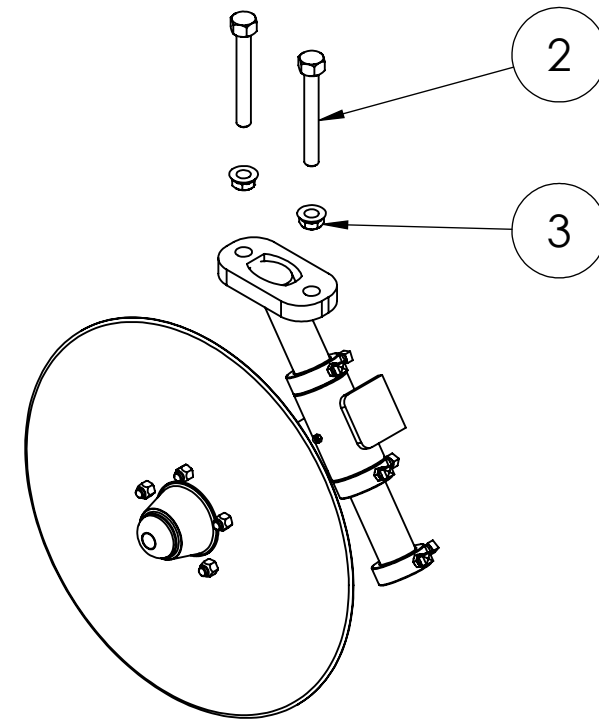

COULTTER
HARDWARE

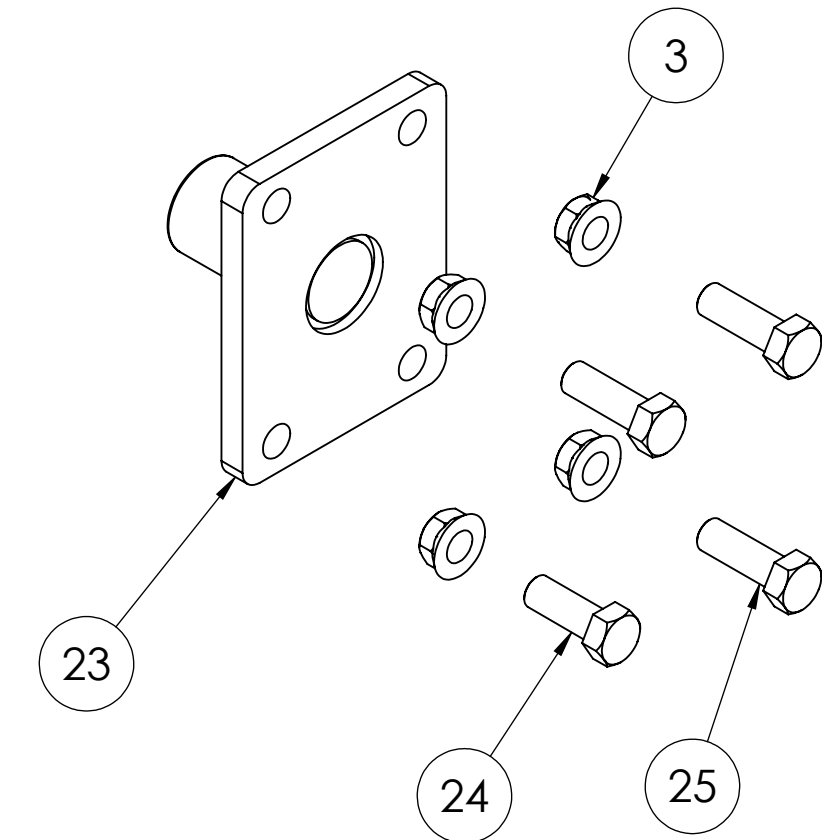

ROCKSHAFT STUDPLATE
HARDWARE

ITEM NO.	PART NUMBER	DESCRIPTION	QTY.
1	MM7000406	9x6 Series III Left Insert Wing	1
2	150016	3/4" x 6" BOLT	2
3	150021	3/4" FLANGE NUT	10
4	MM9000051	SIII Coultter Assembly	1
5	320033	22-1/2" COULTTER BLADE	1
6	150059	1" NUT TOP LOCK	1
7	150080	ROUND SHIM	4
8	150052	1" x 6" BOLT	1
9	150019	3/4" x 6" BOLT	2
10	150082	ROUND SHIM	8
11	150093	3/4" TOP LOCK NUT	2
12	MM8000450	6' STANDARD SERIES III	1
13	MM7000030	PICKER WISHBONE ASSY.	1
14	150002	1-1/8" NUT	2
15	150060	1-1/8" LOCKWASHER	2
16	150158	1-1/8" x 4" BOLT	2
17	150156	1-1/2" JAM NUT	3
18	MM1500001	Wedge Lock Washer	1
19	MM7000269	DEPTH ADJ. ANCHOR BOLT	1
20	MM7000041	HOSE CLAMP NARROW	6
21	150077	3/8" LOCKWASHER	6
22	150332	3/8" x 1-1/4" NF BOLT	6
23	MM7000019	ROCKSHAFT BEARING STUD PLATE	2
24	150057	3/4" x 2" BOLT	1
25	150017	3/4" x 2-1/4" BOLT	7
26	MM8000200	LEFT ROCKSHAFT ASSY. KIT	1
27	150036	1" JAM NUT	2
28	150033	1" LOCKWASHER	2
29	150085	1" x 3-1/2" BOLT	2
30	MM7000282		1

DETAIL R
SCALE 1 : 8

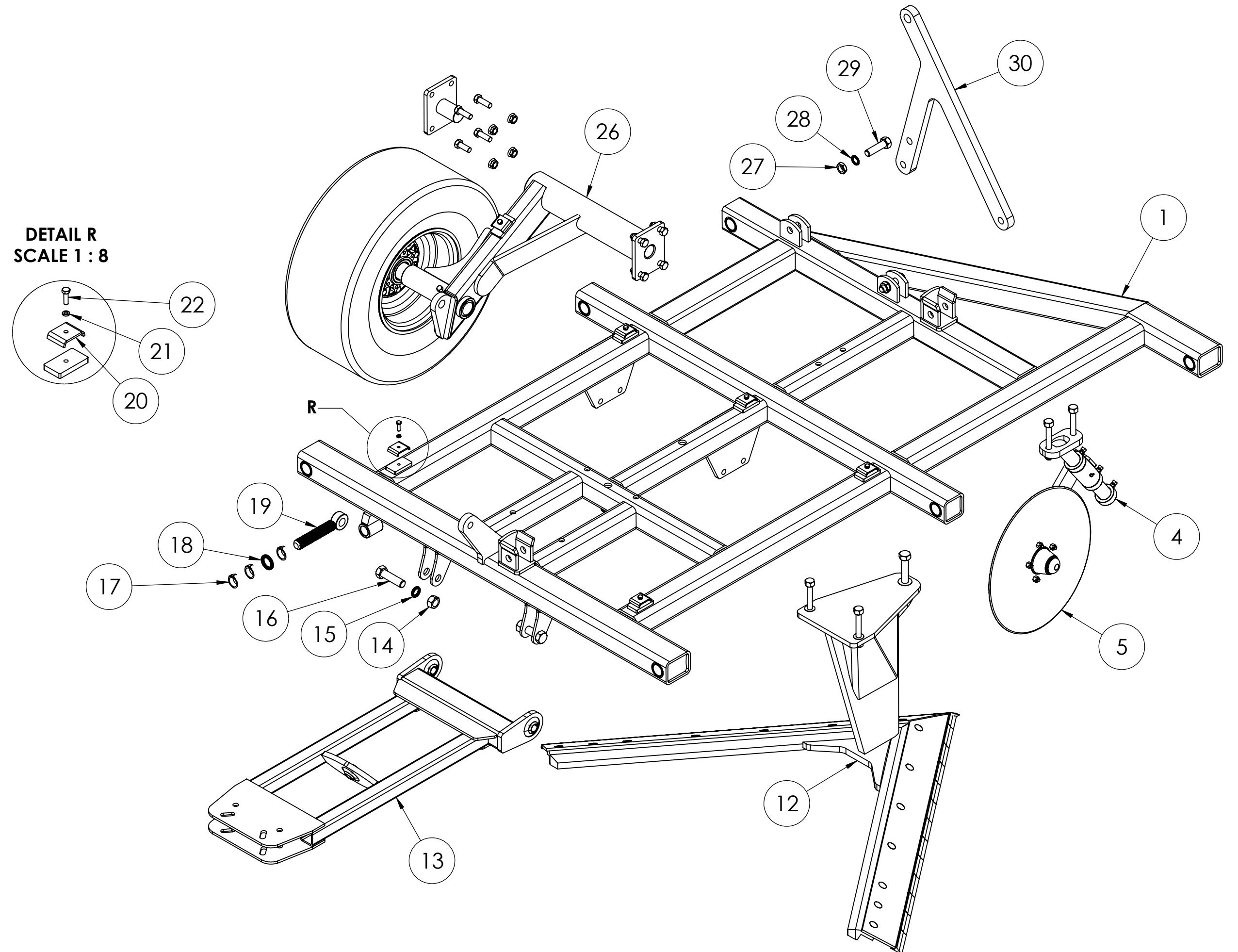

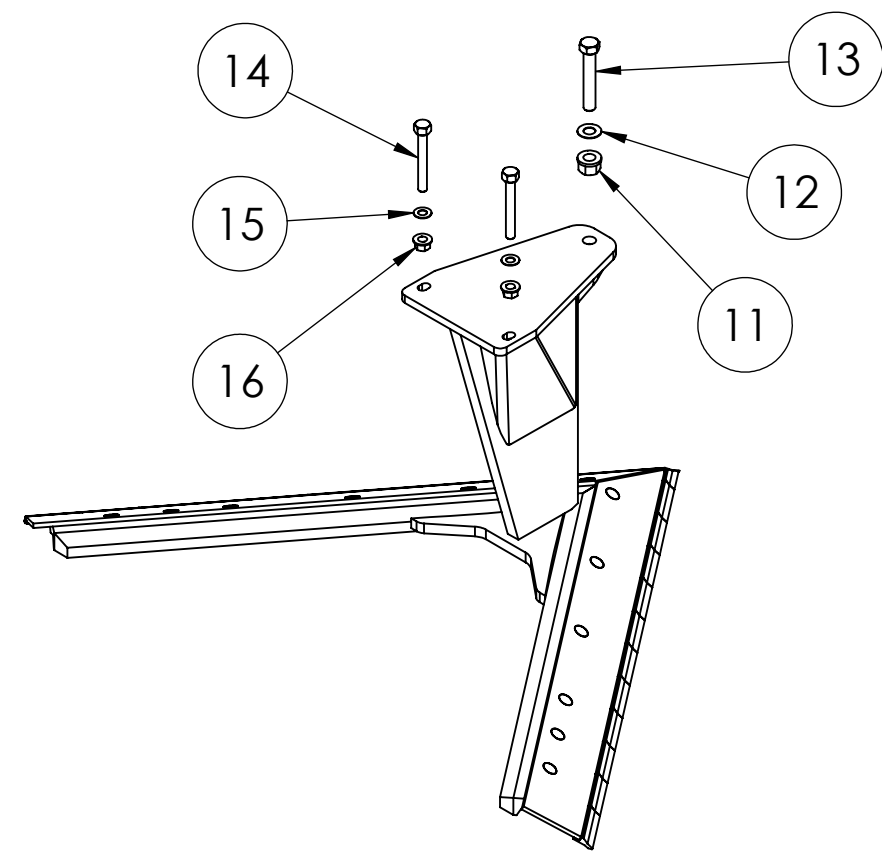

STANDARD
HARDWARE

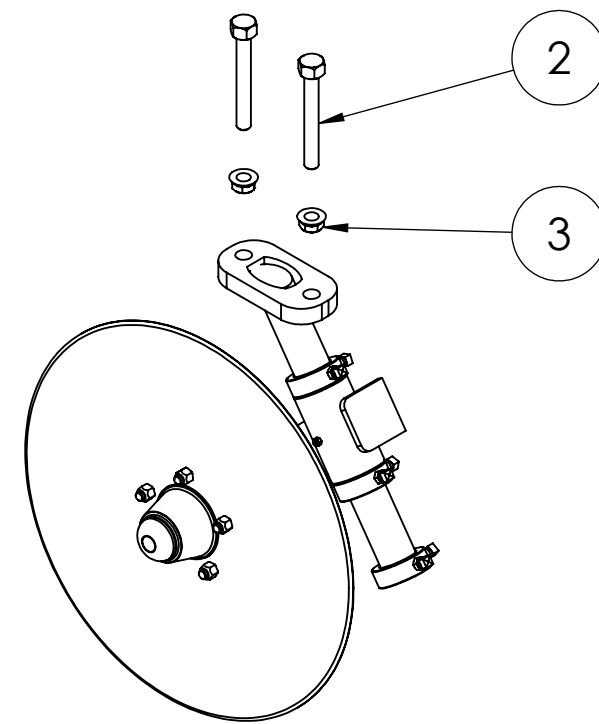

COULTER
HARDWARE

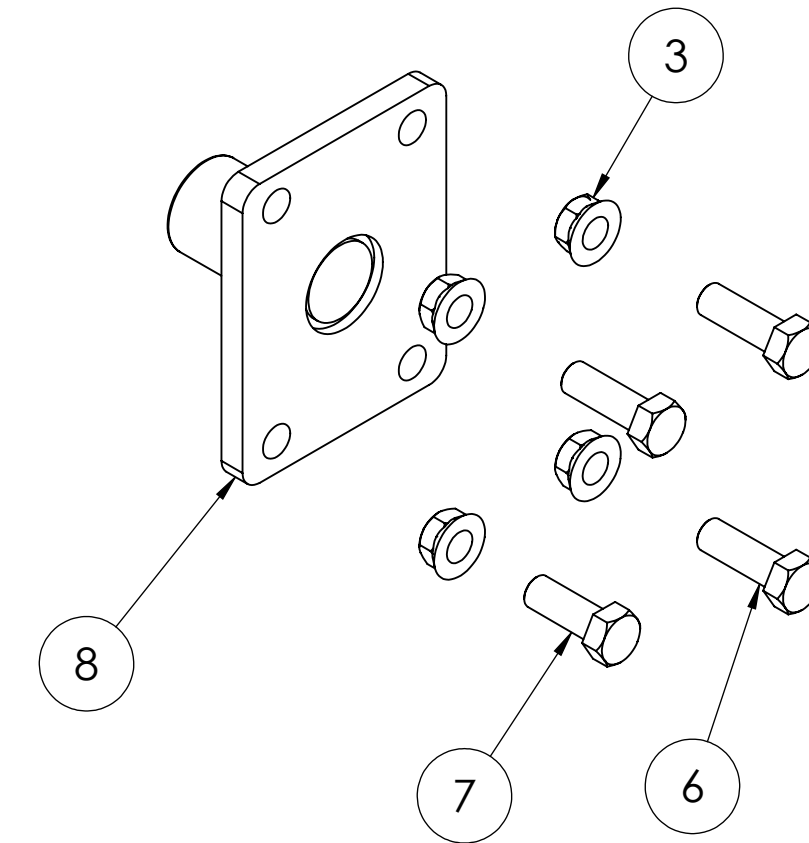

ROCKSHAFT STUDPLATE
HARDWARE

ITEM NO.	PART NUMBER	DESCRIPTION	QTY.
1	MM7000407	9x6 Series III Right outside wing	1
2	150016	3/4" x 6" BOLT	2
3	150021	3/4" FLANGE NUT	10
4	MM9000050	Series III Colter Assembly Complete	1
5	320033	22-1/2" COULTER BLADE	1
6	150017	3/4" x 2-1/4" BOLT	7
7	150057	3/4" x 2" BOLT	1
8	MM7000019	ROCKSHAFT BEARING STUD PLATE	2
9	MM8000201	Right Rockshaft	1
10	MM5000575	STUBBLE RELEASE KNIFE	1
11	150059	1" NUT TOP LOCK	1
12	150080	ROUND SHIM	4
13	150052	1" x 6" BOLT	1
14	150019	3/4" x 6" BOLT	2
15	150082	ROUND SHIM	8
16	150093	3/4" TOP LOCK NUT	2
17	MM8000451	SERIES III 6.5 STANDARD ASSY	1
18	MM7000269	DEPTH ADJ. ANCHOR BOLT	1
19	MM1500001	Wedge Lock Washer	1
20	150156	1-1/2" JAM NUT	3
21	150158	1-1/8" x 4" BOLT	2
22	150060	1-1/8" LOCKWASHER	2
23	150002	1-1/8" NUT	2
24	MM7000030	PICKER WISHBONE ASSY.	1
25	MM7000041	HOSE CLAMP NARROW	4
26	150077	3/8" LOCKWASHER	4
27	150332	3/8" x 1-1/4" NF BOLT	4
28	150172	1-1/4" SAE WASHER	6
29	150006	5/16" x 2-1/2" ROLL PIN	6
30	MM3500024	1-1/4" X 3-1/8" CYLINDER	3
31	MM5000146	6' FRAME FLOP TAB	1
32	MM5000145	SERIES II OUTSIDE FLOP TAB COWBELL	1

DETAIL B
SCALE 1 : 8

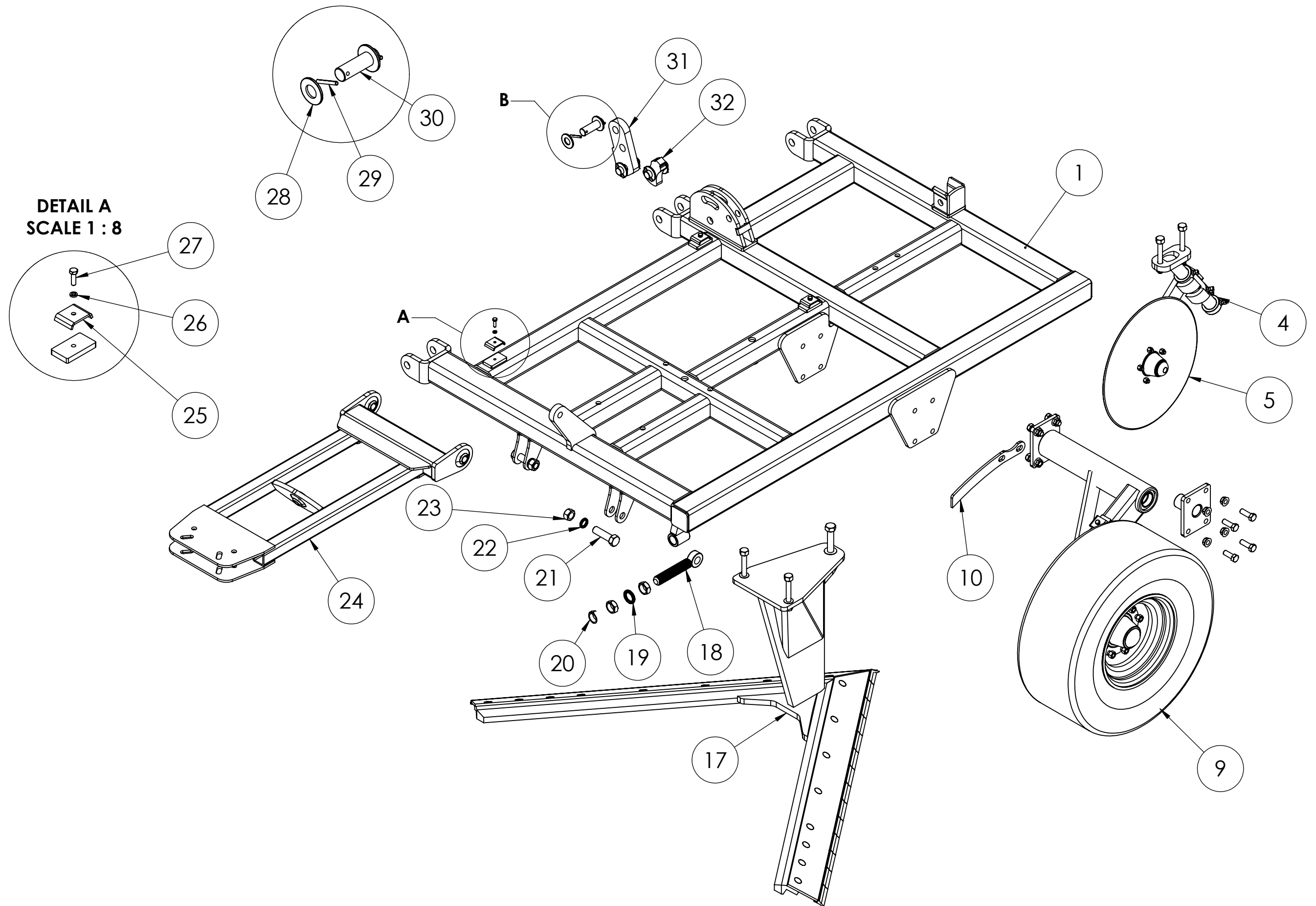

DETAIL A
SCALE 1 : 8

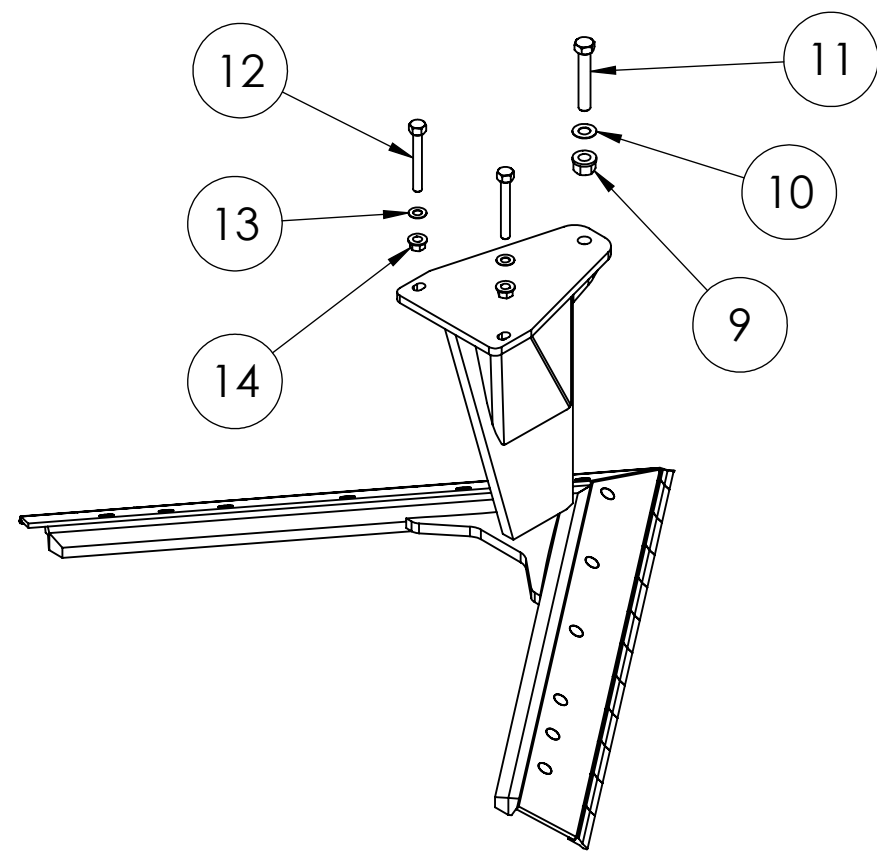

STANDARD
HARDWARE

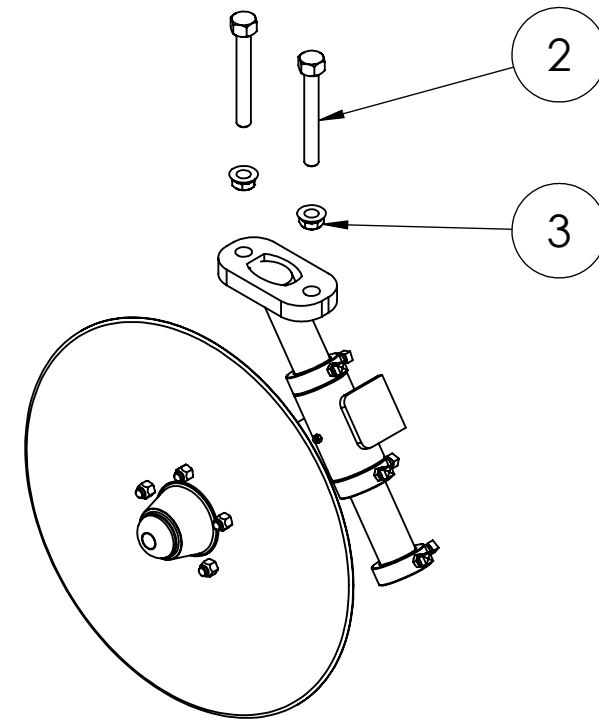

COULTER
HARDWARE

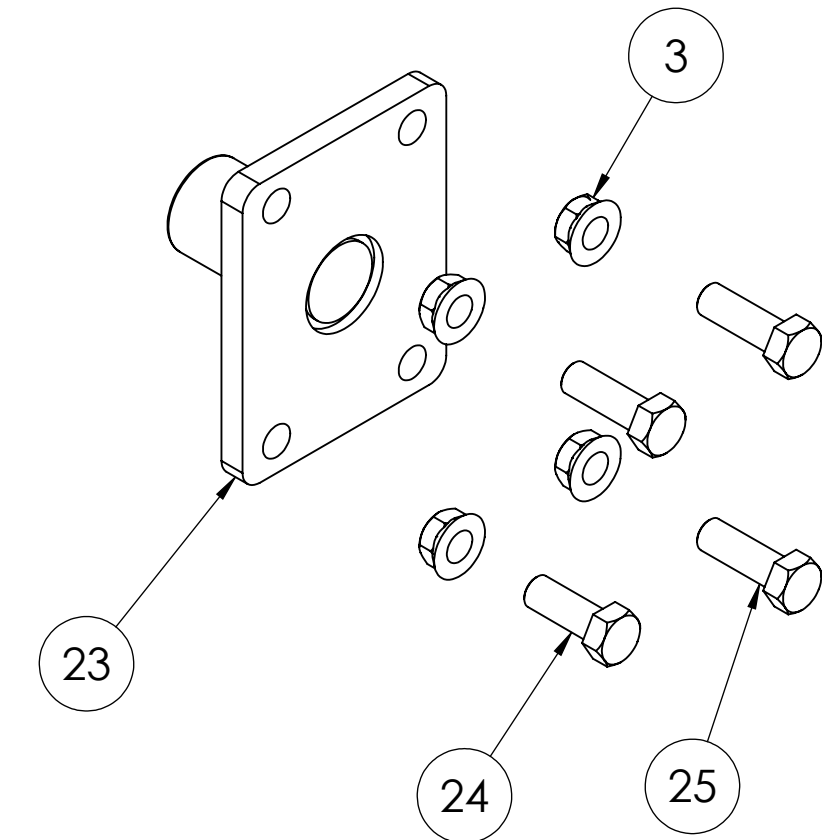

ROCKSHAFT STUDPLATE
HARDWARE

ITEM NO.	PART NUMBER	DESCRIPTION	QTY.
1	MM7000408	9x6 Series III Left outside wing	1
2	150016	3/4" x 6" BOLT	2
3	150021	3/4" FLANGE NUT	10
4	MM9000050	Series III Colter Assembly Complete	1
5	320033	22-1/2" COULTER BLADE	1
6	150332	3/8" x 1-1/4" NF BOLT	4
7	150077	3/8" LOCKWASHER	4
8	MM7000041	HOSE CLAMP NARROW	4
9	150059	1" NUT TOP LOCK	1
10	150080	ROUND SHIM	4
11	150052	1" x 6" BOLT	1
12	150019	3/4" x 6" BOLT	2
13	150082	ROUND SHIM	8
14	150093	3/4" TOP LOCK NUT	2
15	MM8000451	SERIES III 6.5 STANDARD ASSY	1
16	MM7000030	PICKER WISHBONE ASSY.	1
17	150002	1-1/8" NUT	2
18	150060	1-1/8" LOCKWASHER	2
19	150158	1-1/8" x 4" BOLT	2
20	150156	1-1/2" JAM NUT	3
21	MM1500001	Wedge Lock Washer	1
22	MM7000269	DEPTH ADJ. ANCHOR BOLT	1
23	MM7000019	ROCKSHAFT BEARING STUD PLATE	2
24	150057	3/4" x 2" BOLT	1
25	150017	3/4" x 2-1/4" BOLT	7
26	MM8000200	LEFT ROCKSHAFT ASSY. KIT	1
27	MM5000575	STUBBLE RELEASE KNIFE	1
28	MM5000145	SERIES II OUTSIDE FLOP TAB COWBELL	1
29	MM5000146	6' FRAME FLOP TAB	1
30	150172	1-1/4" SAE WASHER	6
31	150006	5/16" x 2-1/2" ROLL PIN	6
32	MM3500024	1-1/4" X 3-1/8" CYLINDER	3

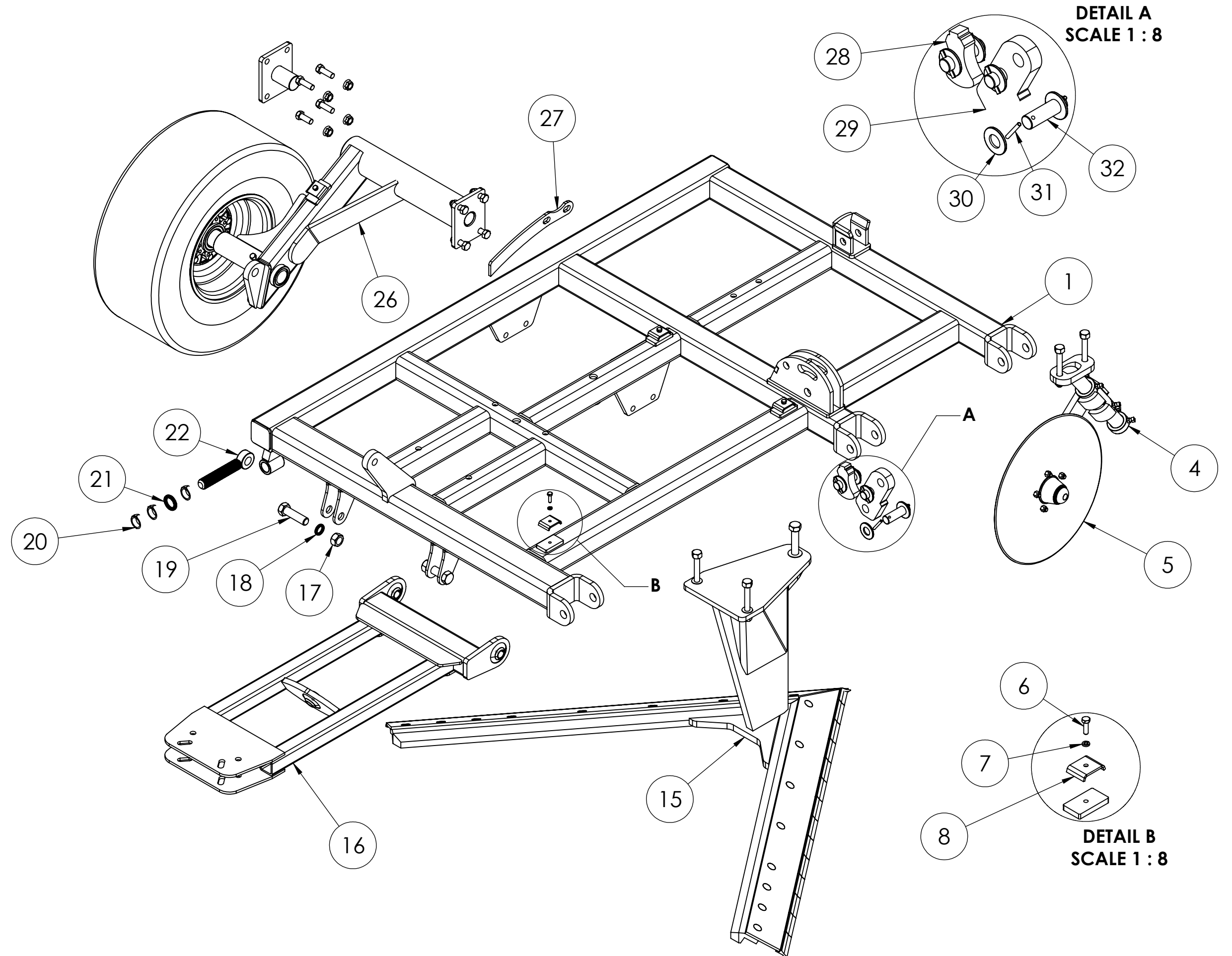

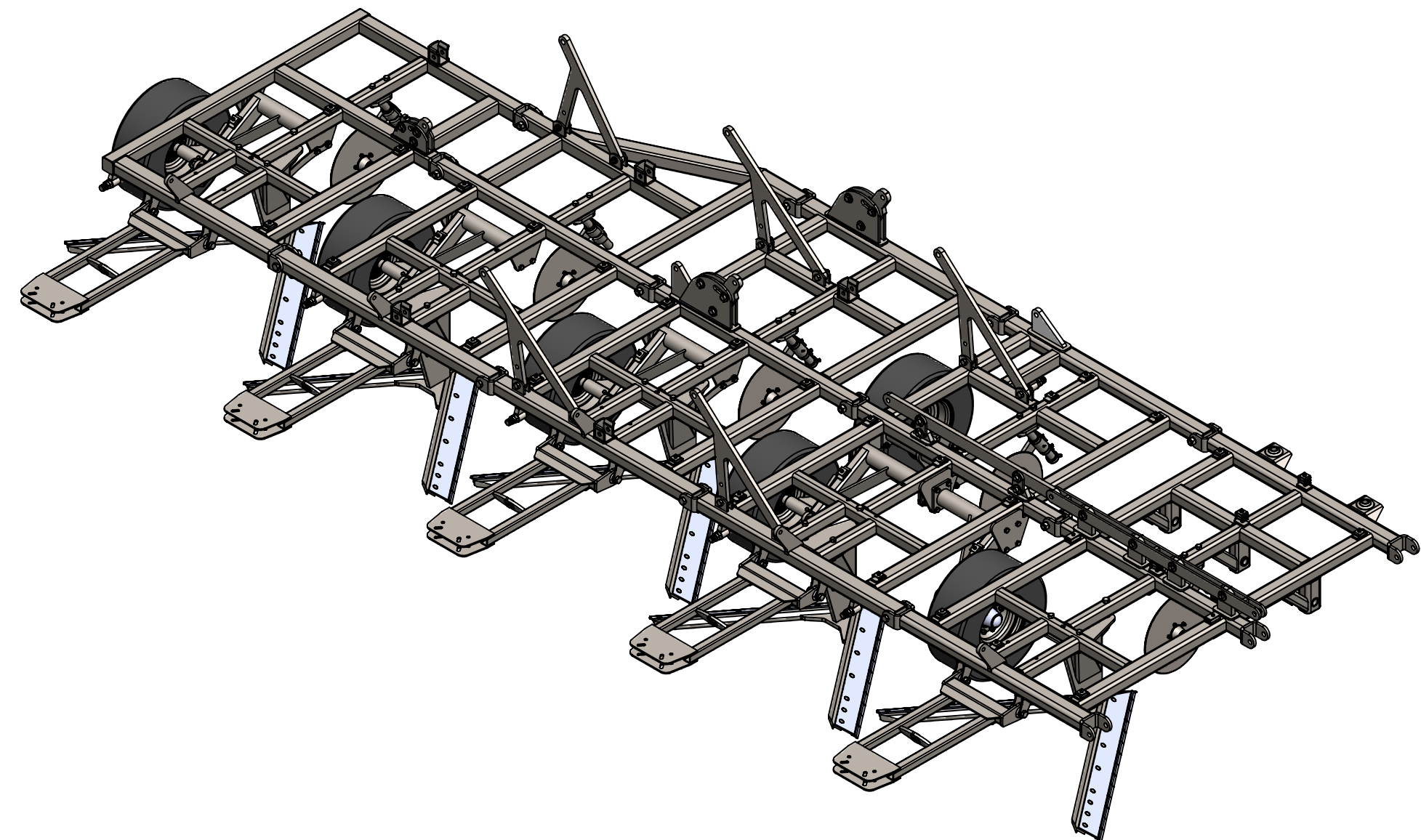
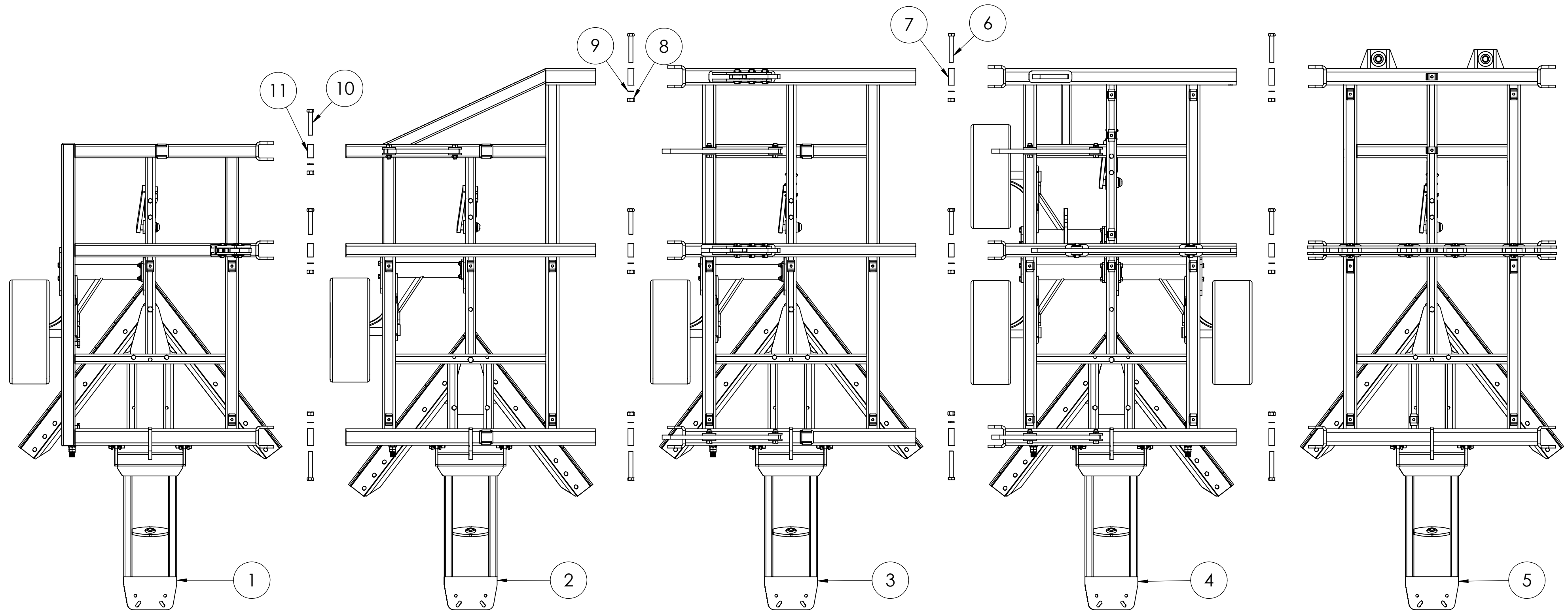

ITEM NO.	PART NUMBER	DESCRIPTION	QTY.
1	MM8000358	9x6 LEFT OUTSIDE WING ASSEMBLY	1
2	MM8000356	9x6 LEFT INSERT WING ASSEMBLY	1
3	MM8000354	9-6' SIII 2021 LEFT CENTER INSERT	1
4	MM8000352	LEFT CENTER FRAME SERIES III 2021	1
5	MM8000350	9x6 CENTER FRAME ASSEMBLY	1
6	150217	1-1/4" x 8" BOLT	7
7	MM5000487	5" LOOSE HINGE BUSHING	7
8	150144	1-1/4" NUT	12
9	150157	1-1/4" LOCKWASHER	12
10	150216	1-1/4" x 7" BOLT	5
11	MM5000488	4" LOOSE HINGE BUSHING	5

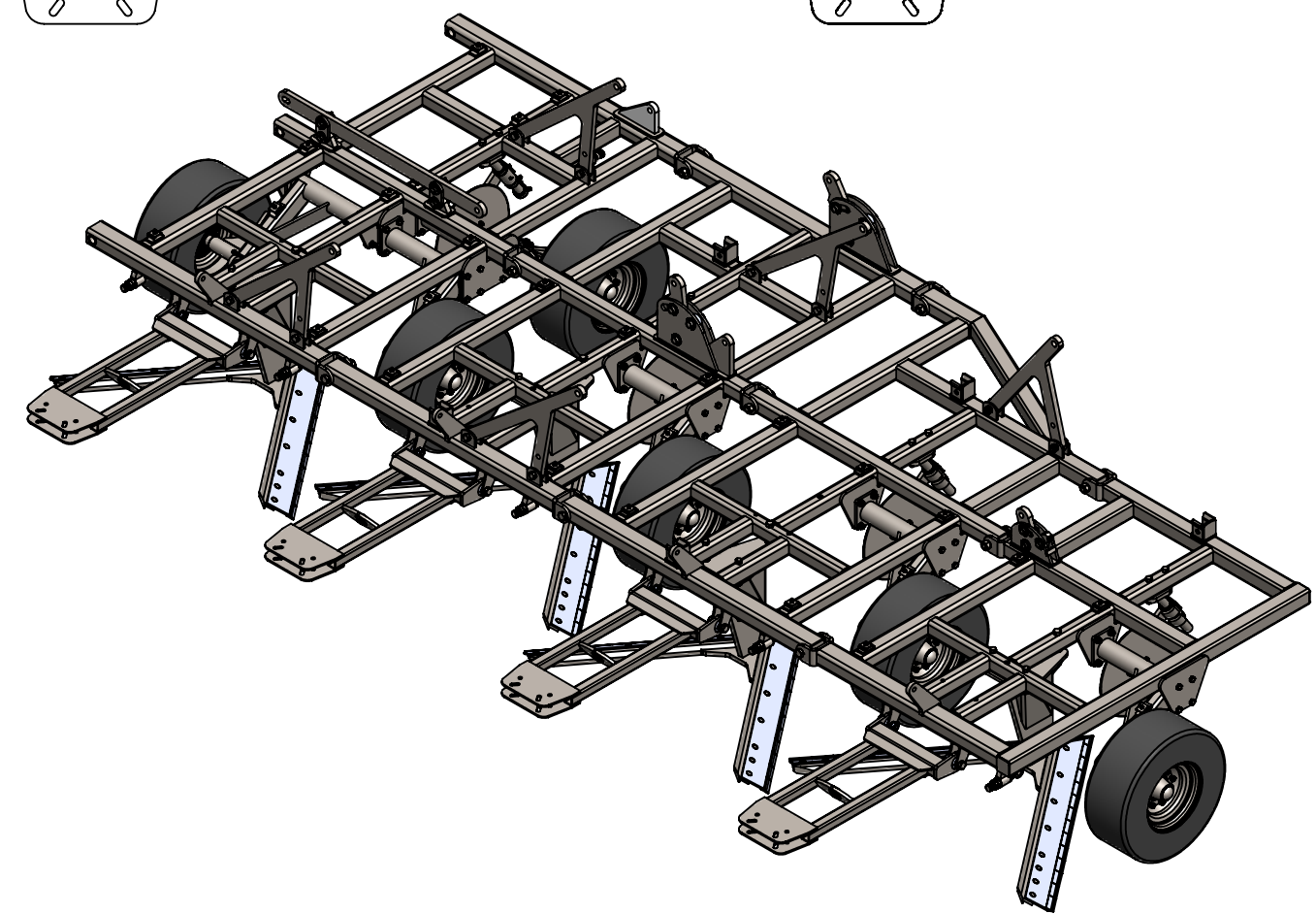
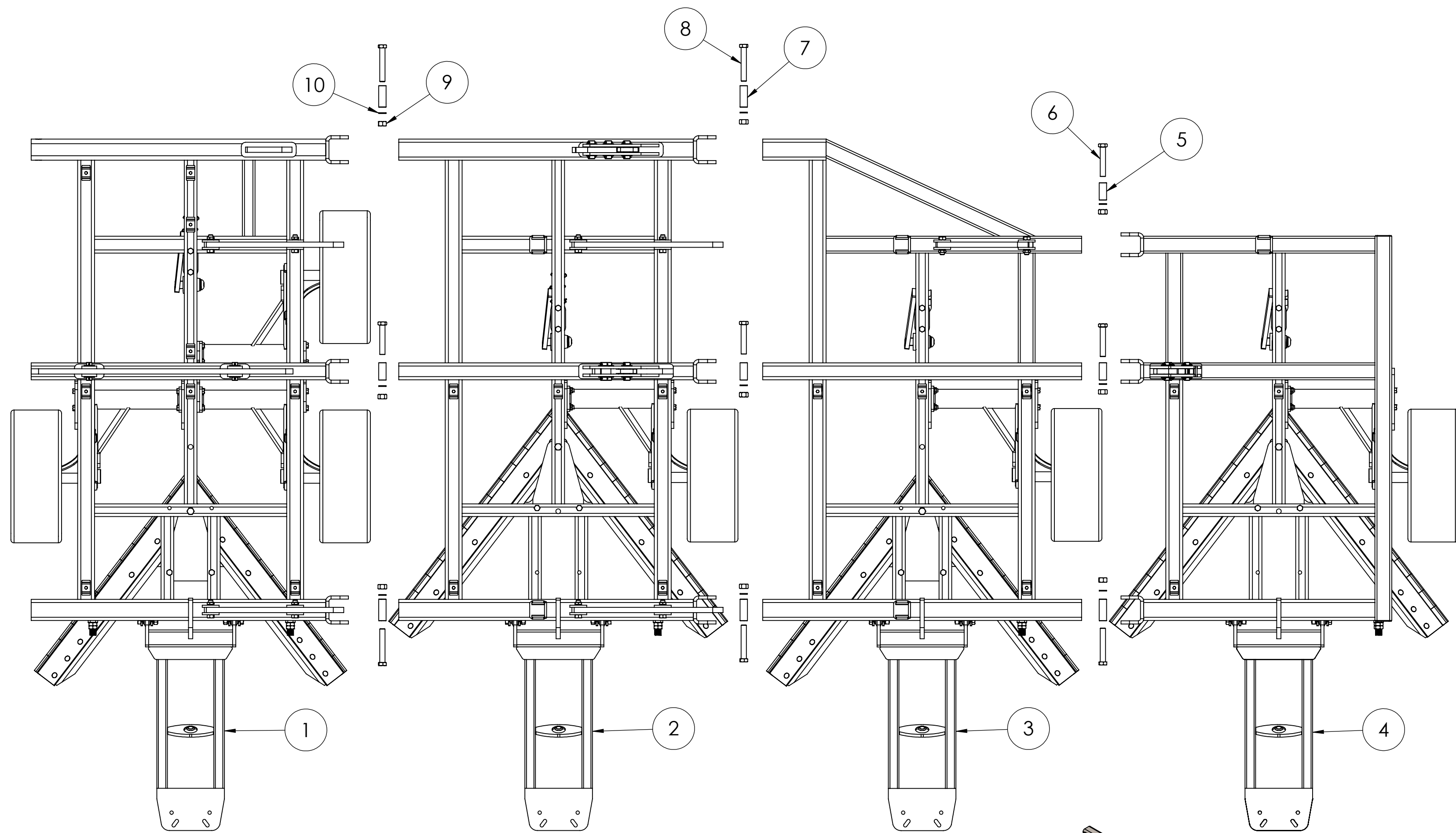

ITEM NO.	PART NUMBER	DESCRIPTION	QTY.
1	MM8000351	9-6' SIII 2021 RIGHT CENTER FRAME COMPLETE	1
2	MM8000353	9-6' SERIES III 2021 9x6 RIGHT INSERT WING ASSEMBLY	1
3	MM8000355	9x6 RIGHT OUTSIDE WING ASSEMBLY	1
4	MM8000357	9x6 RIGHT OUTSIDE WING ASSEMBLY	1
5	MM5000488	4" LOOSE HINGE BUSHING	4
6	150216	1-1/4" x 7" BOLT	4
7	MM5000487	5" LOOSE HINGE BUSHING	5
8	150217	1-1/4" x 8" BOLT	5
9	150144	1-1/4" NUT	9
10	150157	1-1/4" LOCKWASHER	9

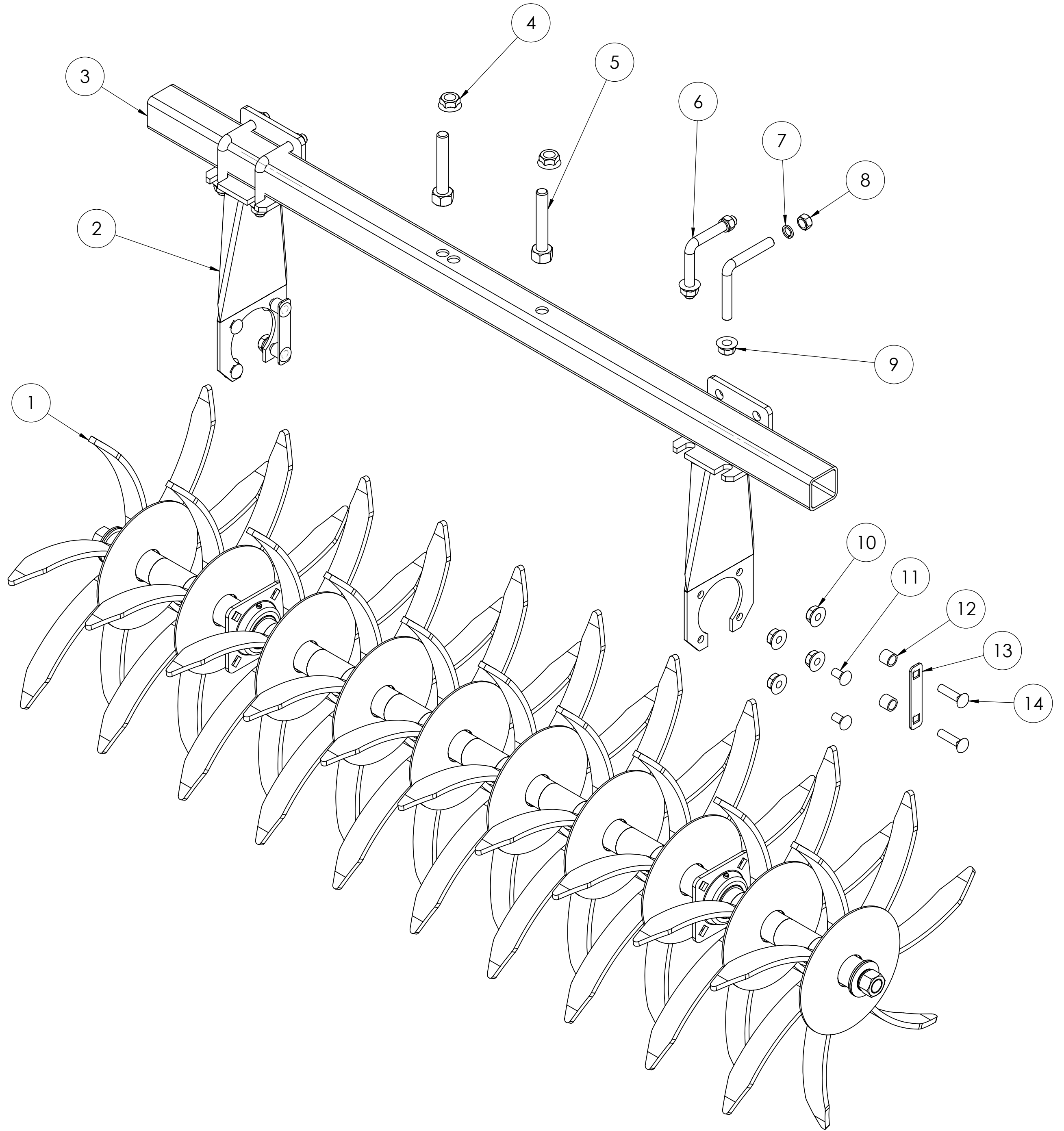
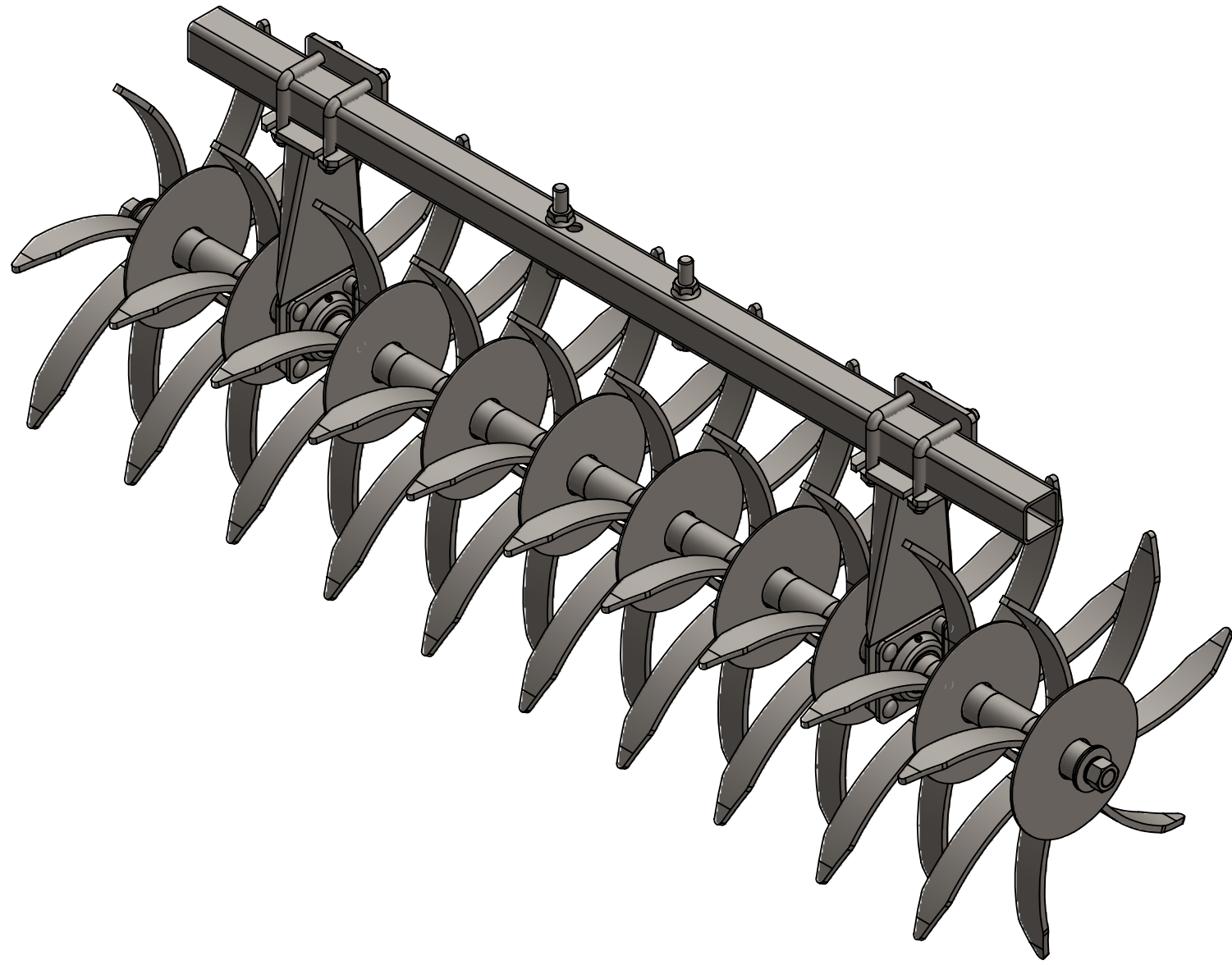

ITEM NO.	PART NUMBER	DESCRIPTION	QTY.
1	MM907210	10 WHEEL RIGHT GANG	1
2	MM7010101	STRUT	2
3	MM5000431	5' OVERTUBE	1
4	150021	3/4" FLANGE NUT	2
5	150090	3/4" x 4-1/2" BOLT	2
6	150257	5/8"x3.25"x3.25" L-BOLT	4
7	150040	5/8" LOCKWASHER	4
8	150041	5/8" NUT	4
9	150010	5/8" FLANGE NUT	4
10	150011	1/2" FLANGE NUT	8
11	150185	1/2"x1" CARRIAGE HD BOLT	4
12	MM5003272	ZERK GUARD SPACER	4
13	MM5003271	ZERK GUARD	2
14	150186	1/2"x 2" CARRIAGE HD BOLT	4

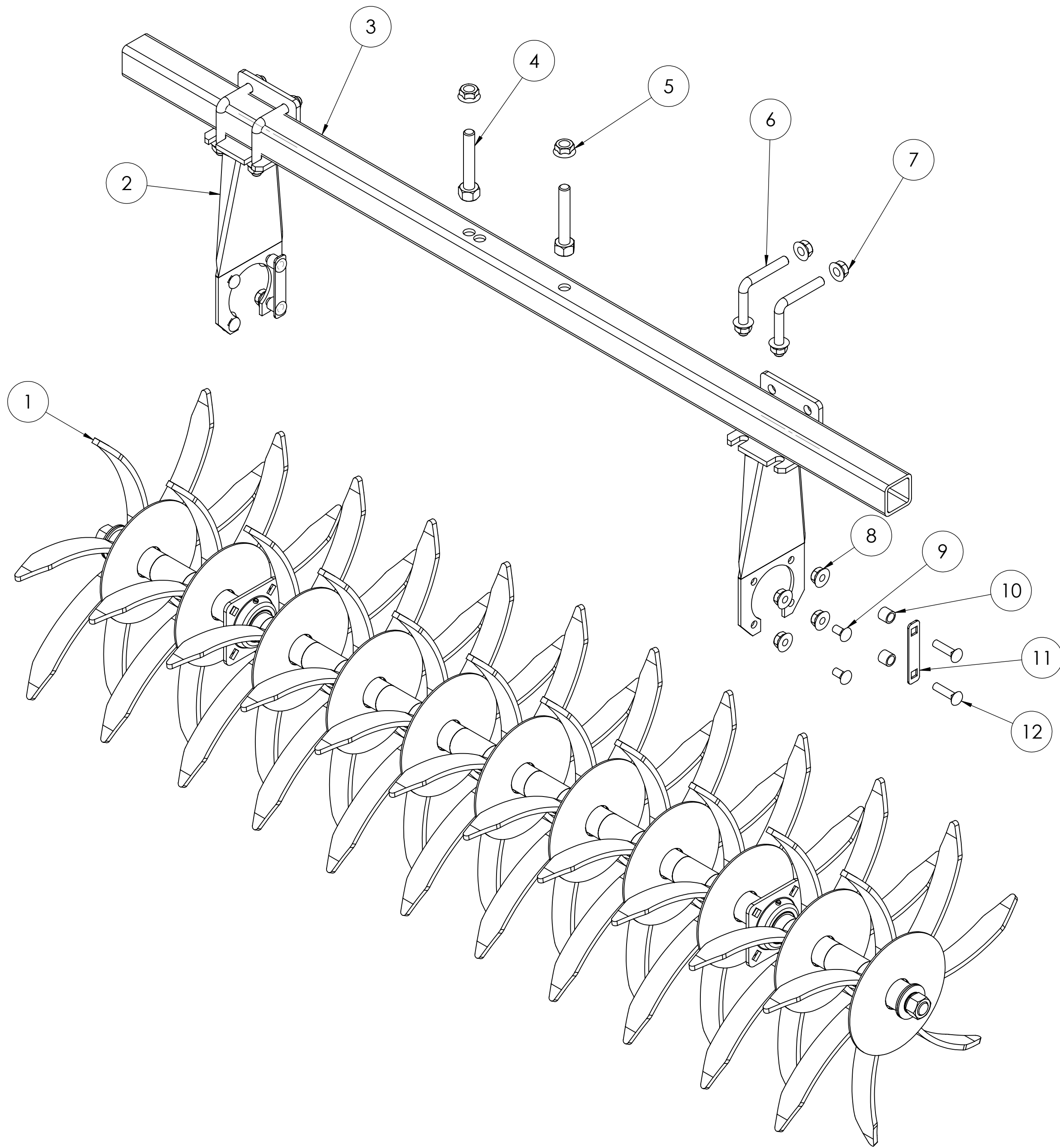
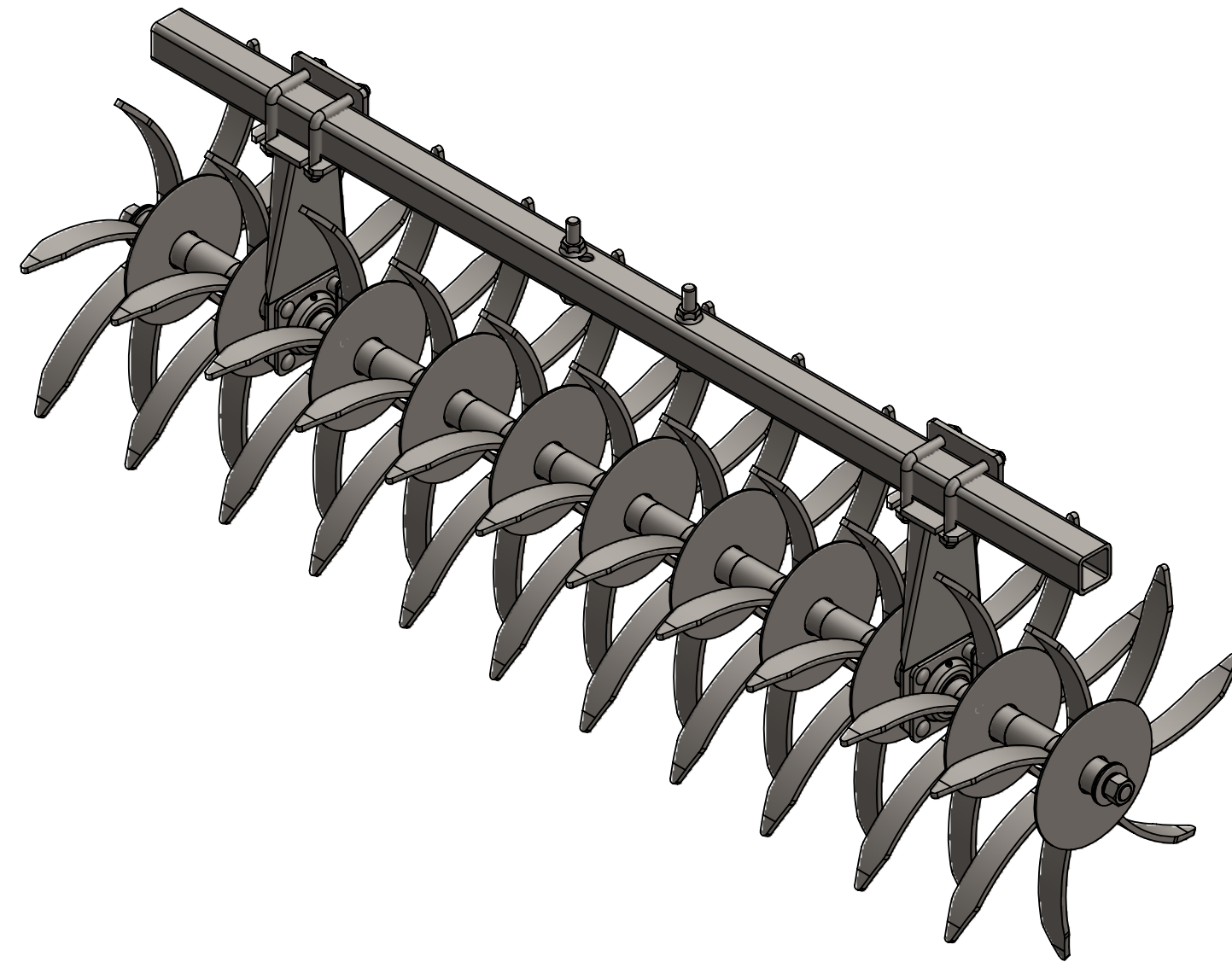

ITEM NO.	PART NUMBER	DESCRIPTION	QTY.
1	MM907211	11 WHEEL LEFT GANG	1
2	MM7010101	STRUT	2
3	MM5000432	6' OVERTUBE	1
4	150090	3/4" x 4-1/2" BOLT	2
5	150021	3/4" FLANGE NUT	2
6	150257	5/8"x3.25"x3.25" L-BOLT	4
7	150010	5/8" FLANGE NUT	8
8	150011	1/2" FLANGE NUT	8
9	150185	1/2"x1" CARRIAGE HD BOLT	4
10	MM5003272	ZERK GUARD SPACER	4
11	MM5003271	ZERK GUARD	2
12	150186	1/2"x 2" CARRIAGE HD BOLT	4

11 WHEEL LEFT GANG MM907201

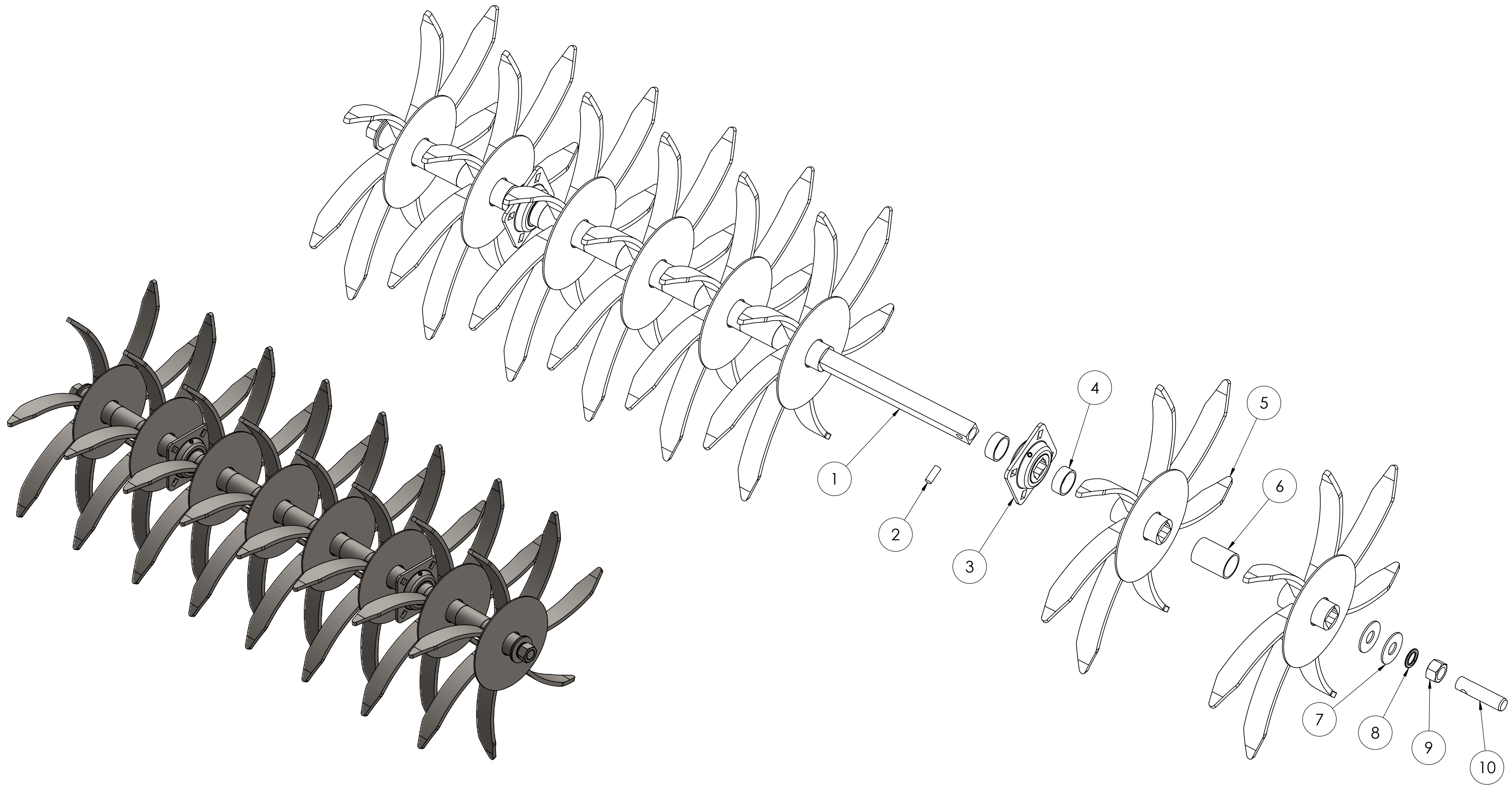

ITEM NO.	PART NUMBER	DESCRIPTION	QTY.
1	MM5001122	PICKER SHAFT 8 WHEEL	1
2	MM5001195	1/2" PIN	2
3	311007	1 1/4" BEARING	2
4	MM5001255	3/4" SPACER	4
5	MM7020980	SERIES II PICKER WHEEL	8
6	MM5001256	2 7/8" SPACER	5
7	150170	1" SAE FLAT WASHER	4
8	150033	1" LOCKWASHER	2
9	150035	1" LOCK NUT	2
10	MM3510020	NEW STYLE THREADED STUD	2

PICKER GANG ASSY.

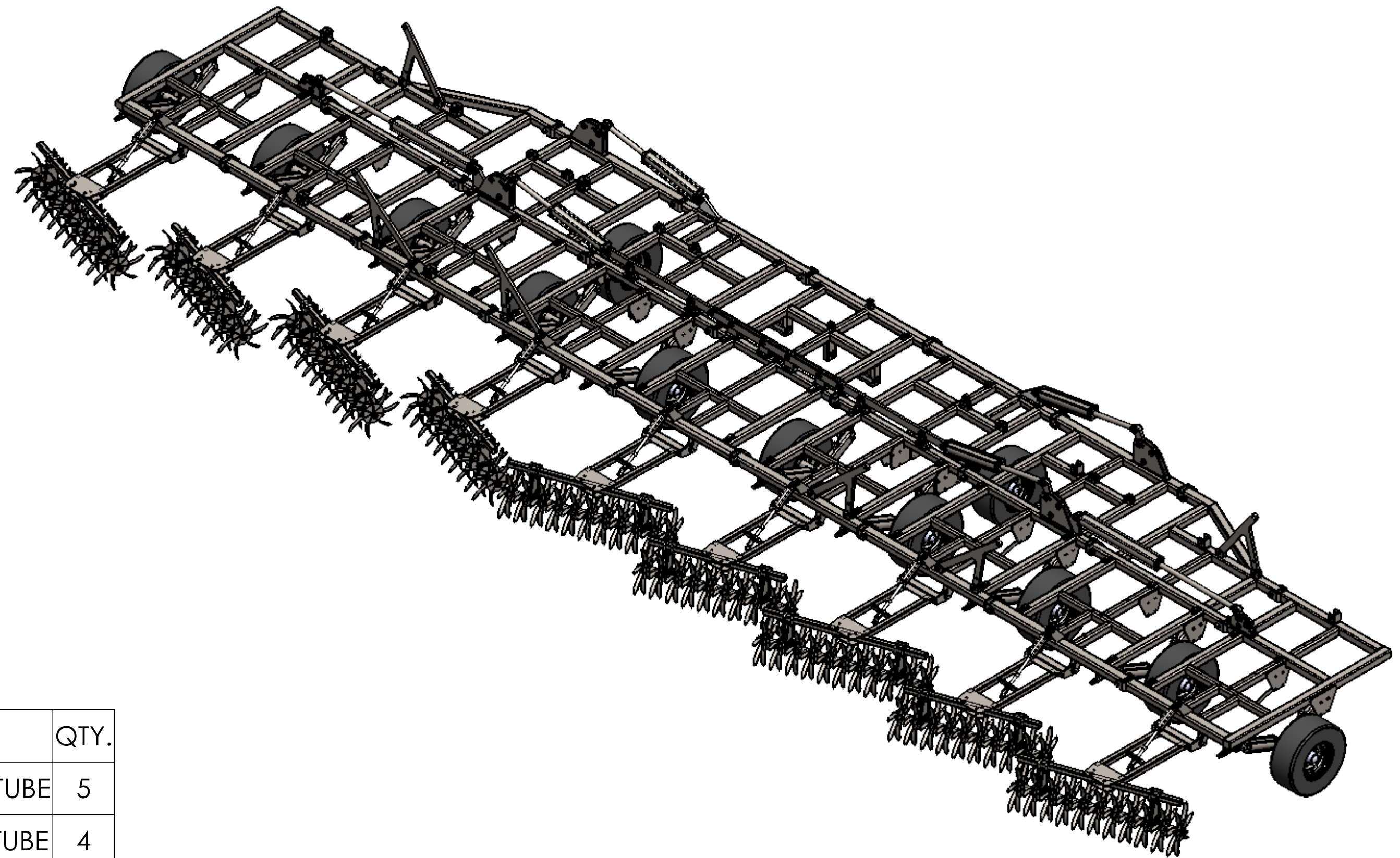
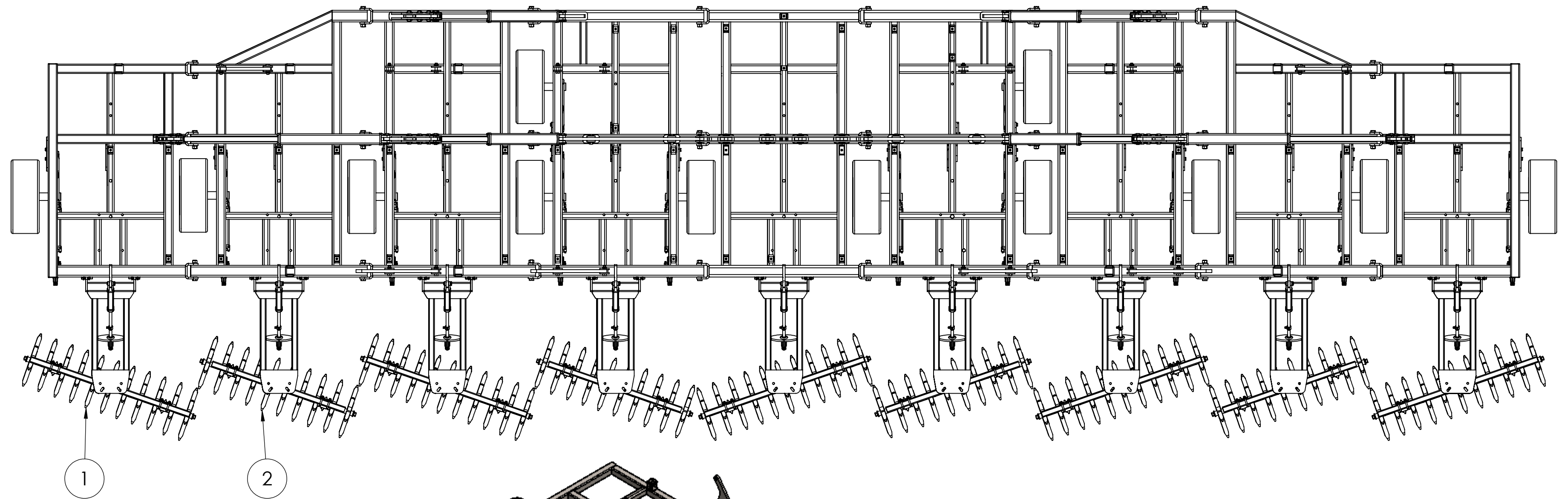

ITEM NO.	PART NUMBER	DESCRIPTION	QTY.
1	MM907201	11 WHEEL R. GANG & 6' OVERTUBE	5
2	MM907200	10 WHEEL L. GANG & 5' OVERTUBE	4

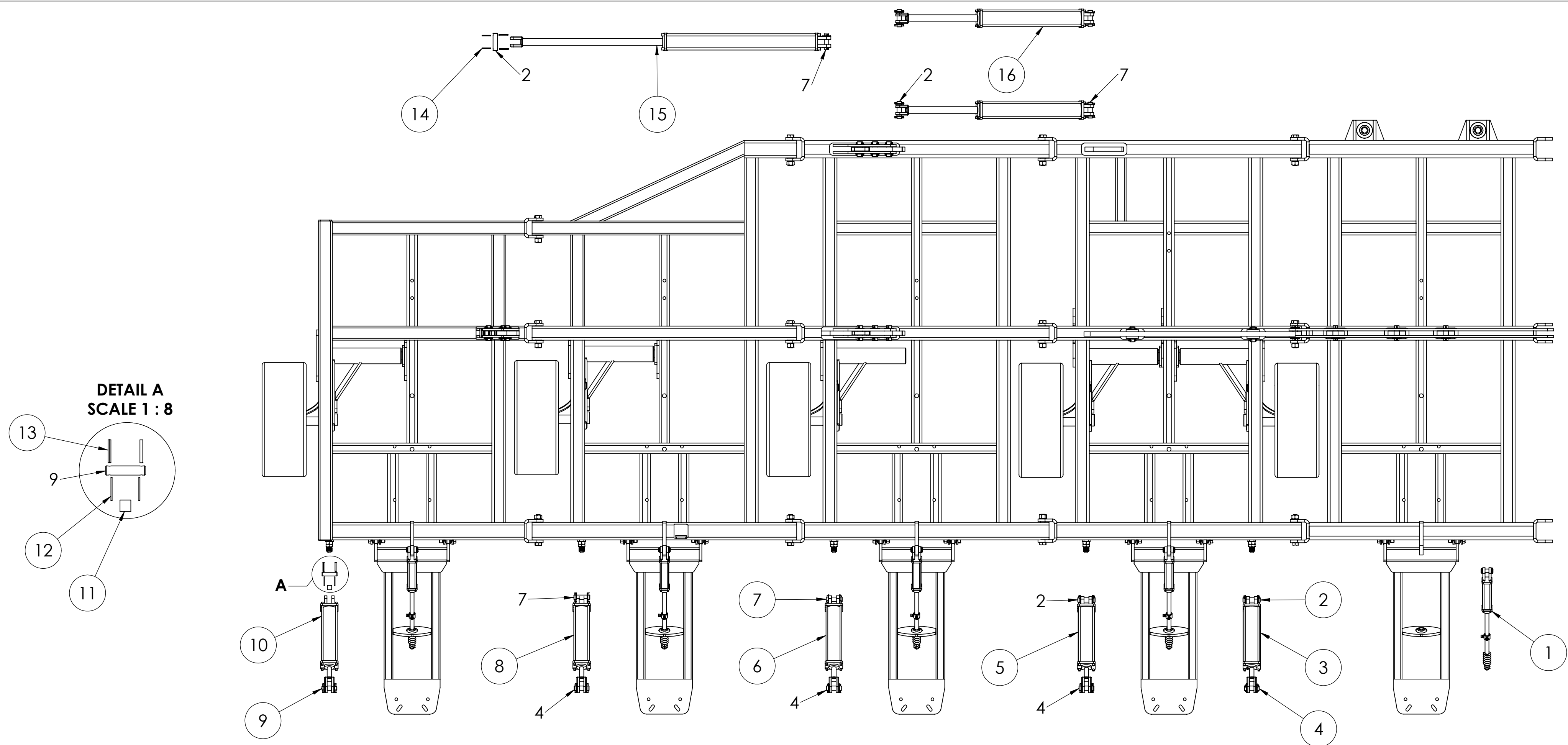

ITEM NO.	PART NUMBER	DESCRIPTION	QTY.
1	MM9020001	PICKER LIFT CYLINDER ASSEMBLY	9
2	MM3500030	1.25" x 3.8125" PIN FOLD CYLINDER BASE	8
3	MM3500052	4.5" x 14" RH DEPTH CYLINDER	2
4	MM3500024	1-1/4" X 3-1/8" CYLINDER	6
5	MM3500050	4.25" X 14 RH DEPTH CYLINDER	2
6	MM3500048	4" x 14" RH DEPTH CYLINDER	2
7	MM3500026	1.25" x 3.4375" PIN	14
8	MM3500046	3.75"x14" RH DEPTH CYLINDER	2
9	MM3500027	1" x 3.036" PIN LIFT CYLINDER BASE	4
10	MM3500044	3.5" x 14" RH DEPTH CYLINDER	2
11	MM5000485	1.25"x 1.1875" LOOSE BUSHING	4
12	150170	1" SAE FLAT WASHER	8
13	150006	5/16" x 2-1/2" ROLL PIN	76
14	150172	1-1/4" SAE WASHER	68
15	MM3500002	4" x 40" CYLINDER 6' OUTSIDE FOLD	2
16	MM3500037	4"X24" CYLINDER	4

NOTE: CYLINDERS AND HARDWARE ARE MIRRORED ABOUT THE CENTER FRAME

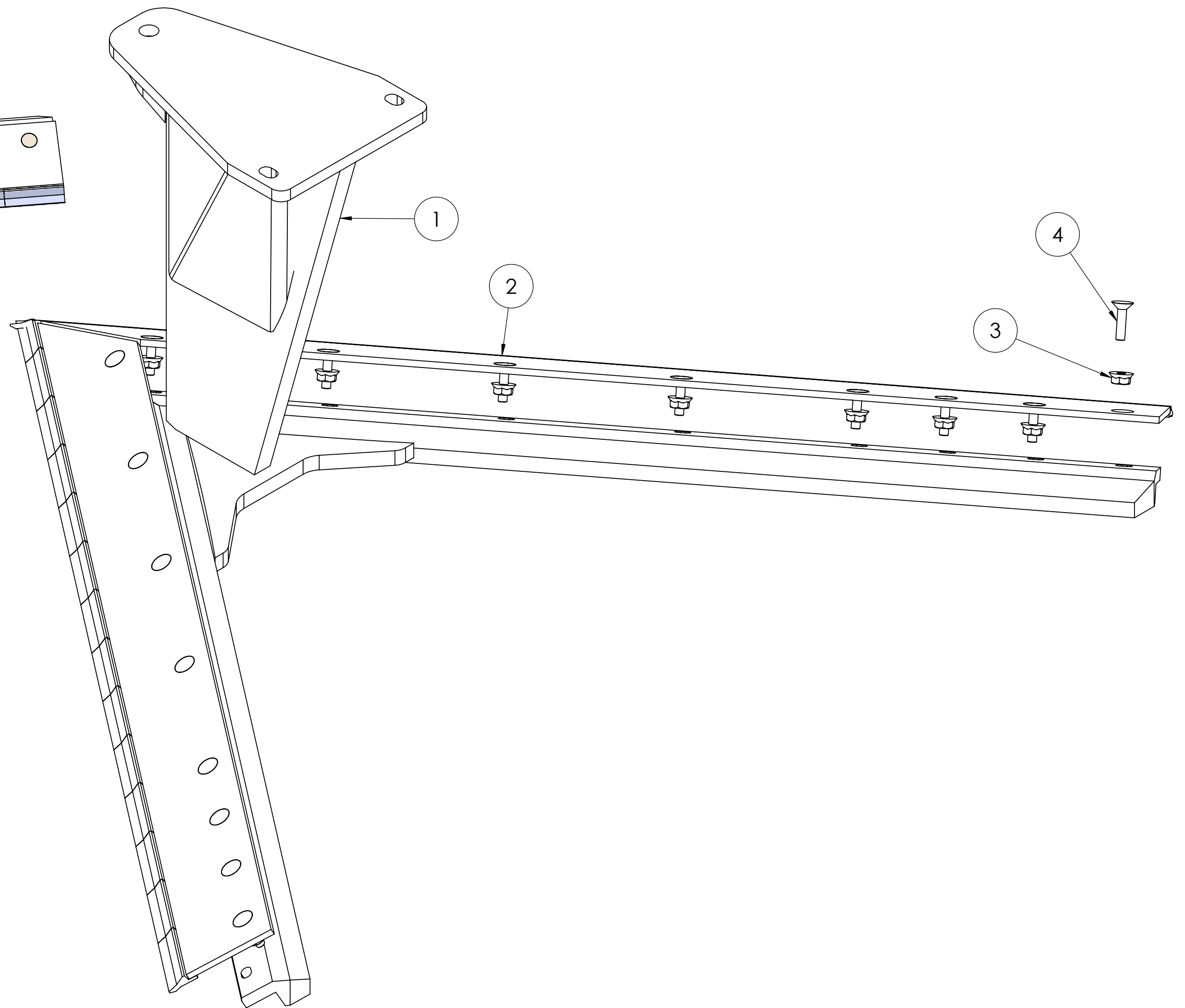
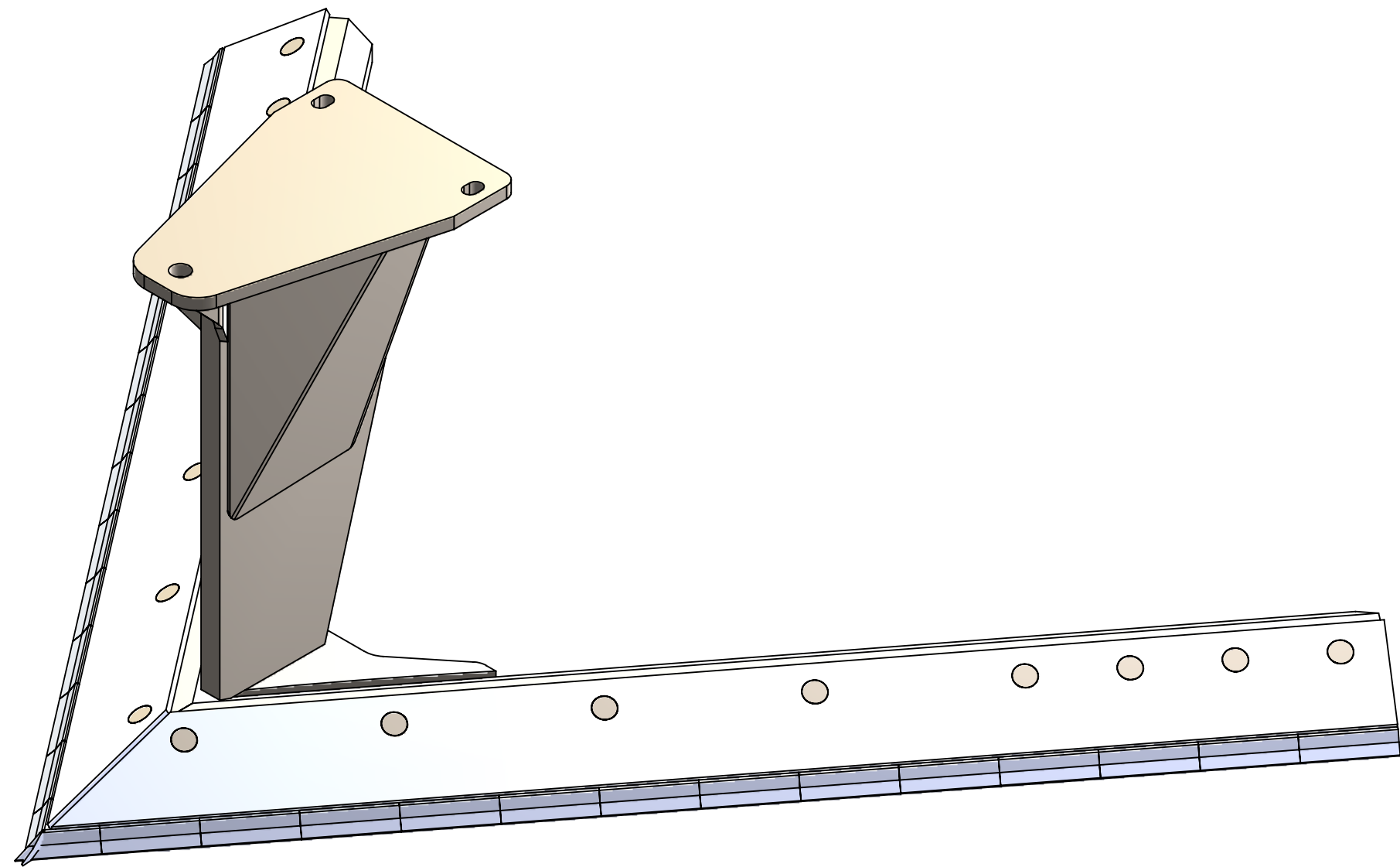

ITEM NO.	PART NUMBER	DESCRIPTION	QTY.
1	MM7000520	Series III 6.5 Standard Complete	1
2	PT802006	6.5' STANDARD BLADE	1
3	150011	1/2" FLANGE NUT	16
4	150025	1/2"x 1-3/4" PLOW BOLT	16

6.5' STANDARD WITH BLADE MM8000451

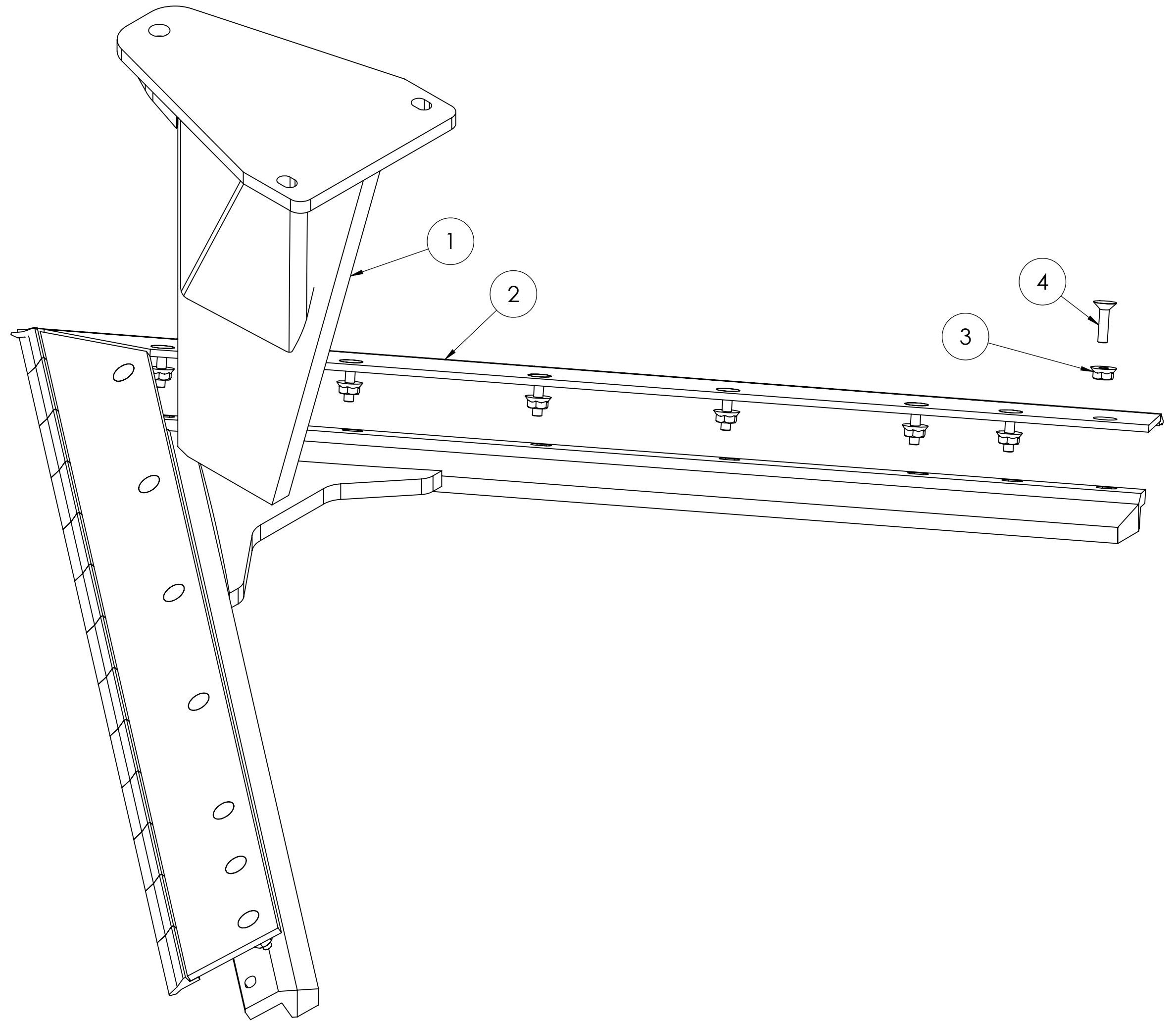
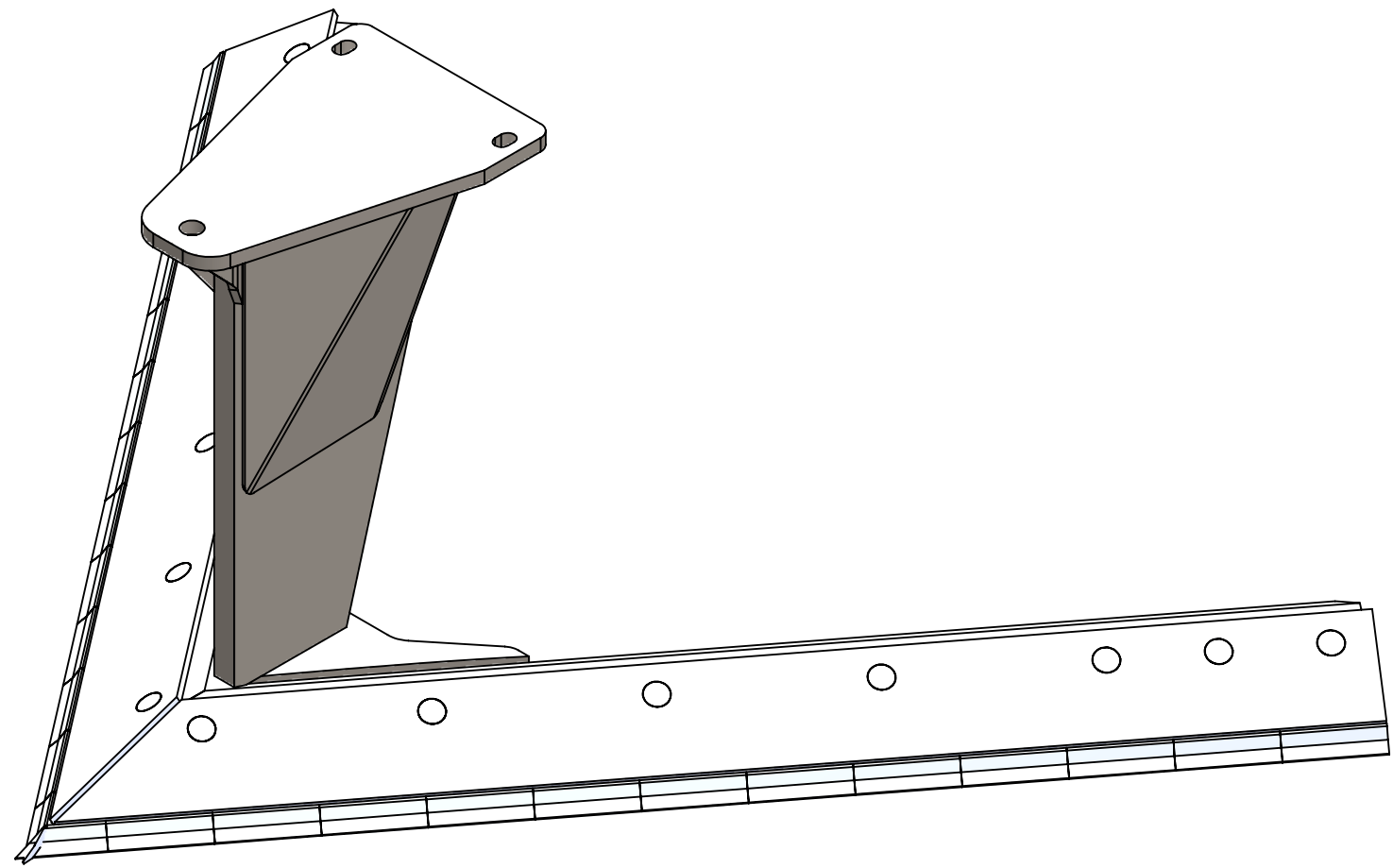

ITEM NO.	PART NUMBER	DESCRIPTION	QTY.
1	MM7000521	Series III 6' Standard Complete	1
2	PT802005	6' STANDARD BLADE	1
3	150011	1/2" FLANGE NUT	14
4	150025	1/2"x 1-3/4" PLOW BOLT	14

6' STANDARD WITH BLADE MM8000450

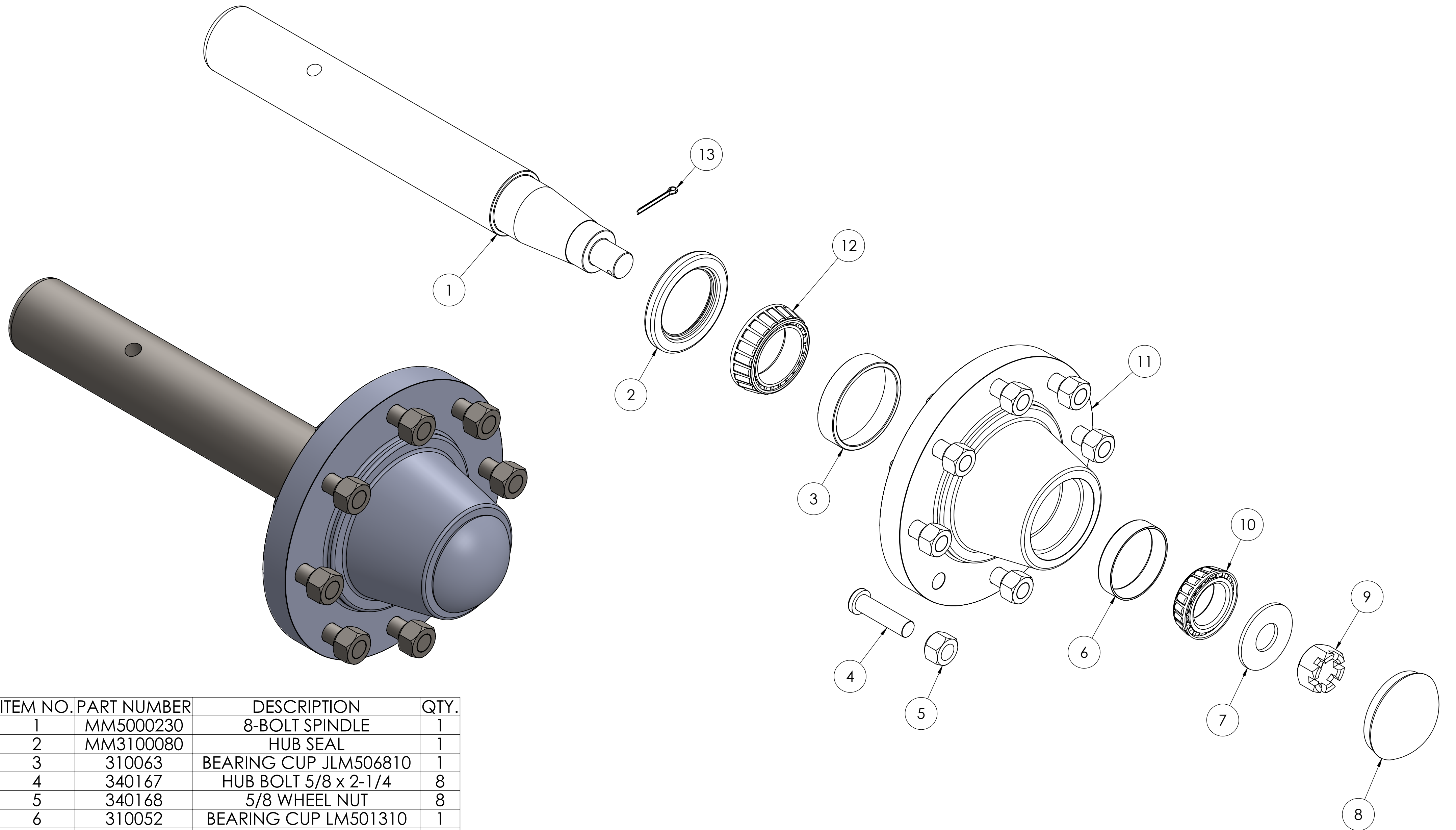

ITEM NO.	PART NUMBER	DESCRIPTION	QTY.
1	MM5000230	8-BOLT SPINDLE	1
2	MM3100080	HUB SEAL	1
3	310063	BEARING CUP JLM506810	1
4	340167	HUB BOLT 5/8 x 2-1/4	8
5	340168	5/8 WHEEL NUT	8
6	310052	BEARING CUP LM501310	1
7	340165	RETAINING WASHER	1
8	340162	HUB CAP	1
9	340166	1"CASTLE NUT	1
10	310051	CONE BEARING LM501349	1
11	MM3500090	8-BOLT HUB	1
12	310062	CONE BEARING JLM506849	1
13	150024	COTTER PIN	1

8 BOLT HUB & SPINDLE ASSEMBLY MM8000001

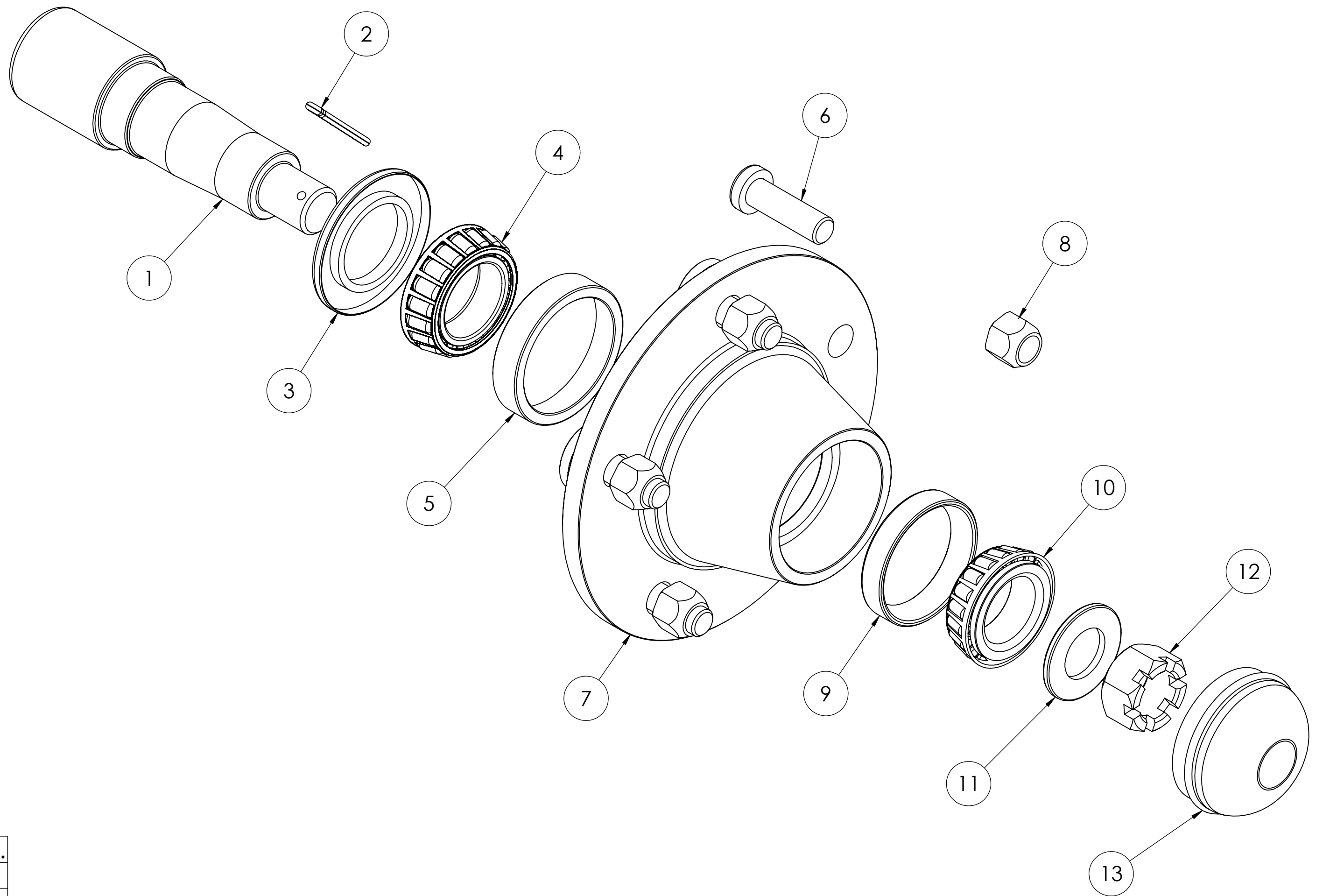
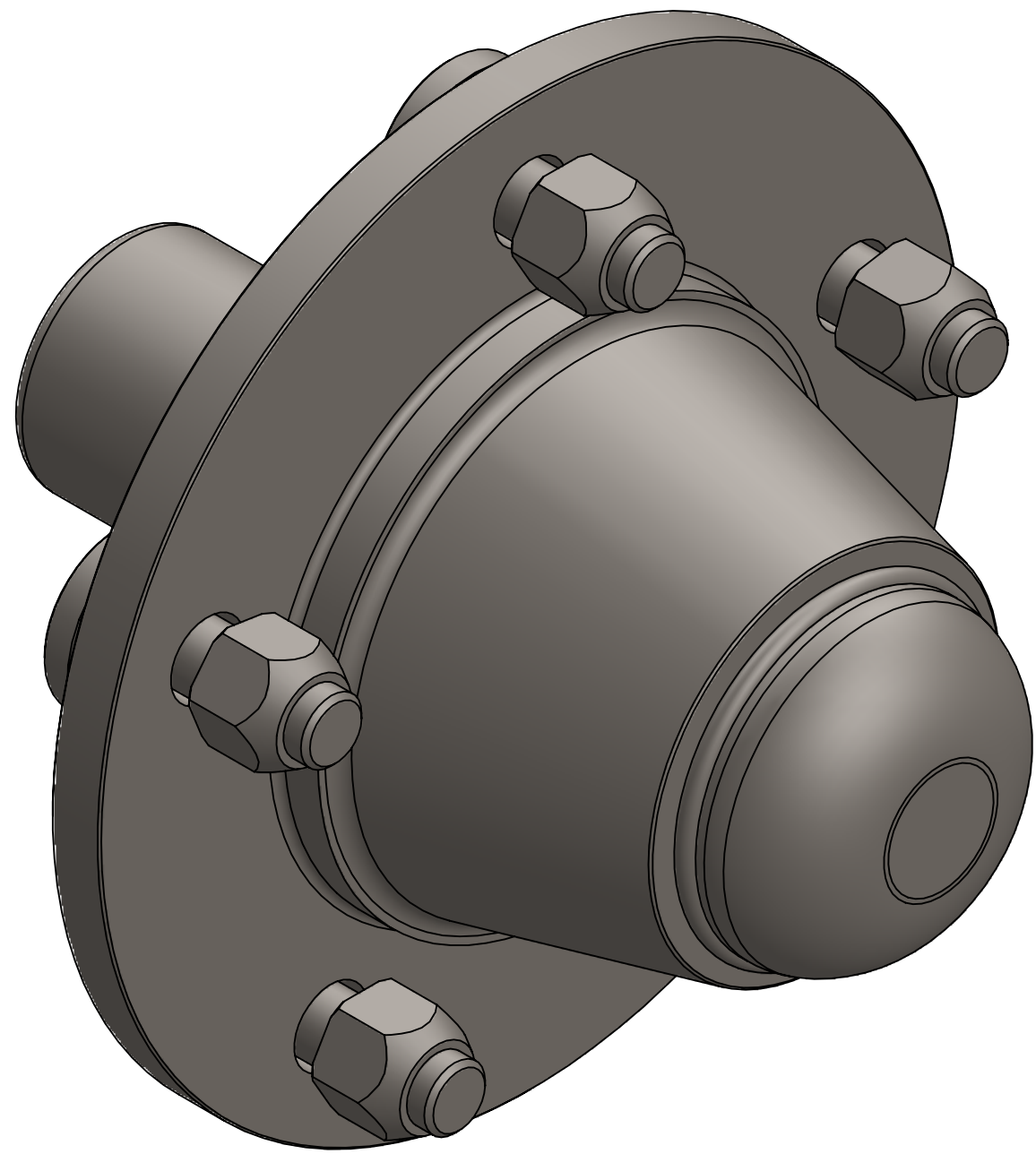

ITEM NO.	PART NUMBER	DESCRIPTION	QTY.
1	MM3400073	SPINDLE 5 BOLT	1
2	150022	COTTER PIN	1
3	310068	SEAL	1
4	310033	CONE BEARING LM48548	1
5	310034	BEARING CUP LM48510	1
6	340049	1/2" x 1-5/8" WHEEL BOLT	5
7	MM3400090	5 BOLT HUB	1
8	340050	1/2" WHEEL NUT	5
9	310035	BEARING CUP LM67010	1
10	310036	CONE BEARING LM67048	1
11	340051	7/8" FLAT WASHER	1
12	340052	7/8" SPINDLE NUT	1
13	340053	HUB CAP	1

5 BOLT HUB ASSEMBLY

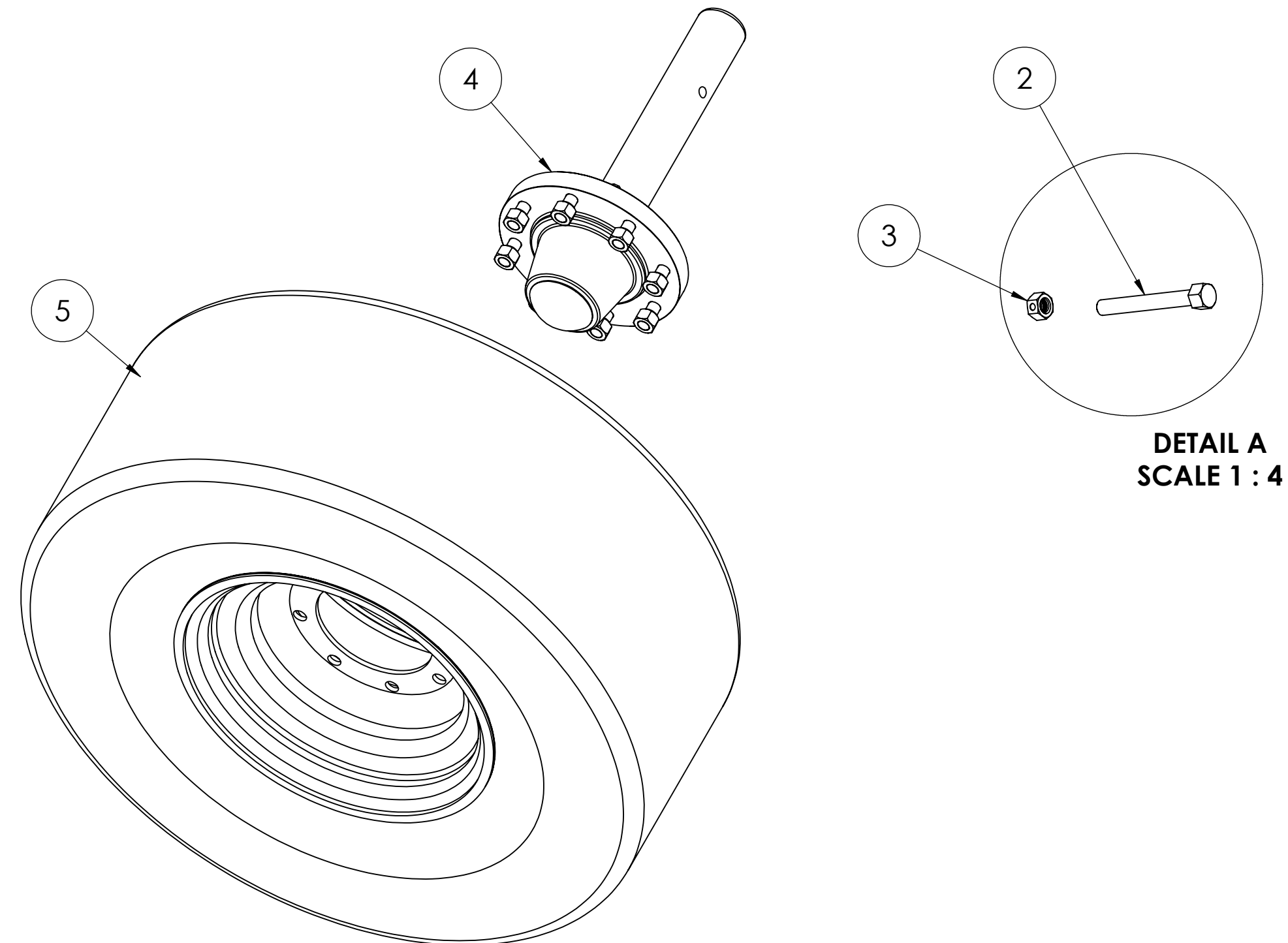
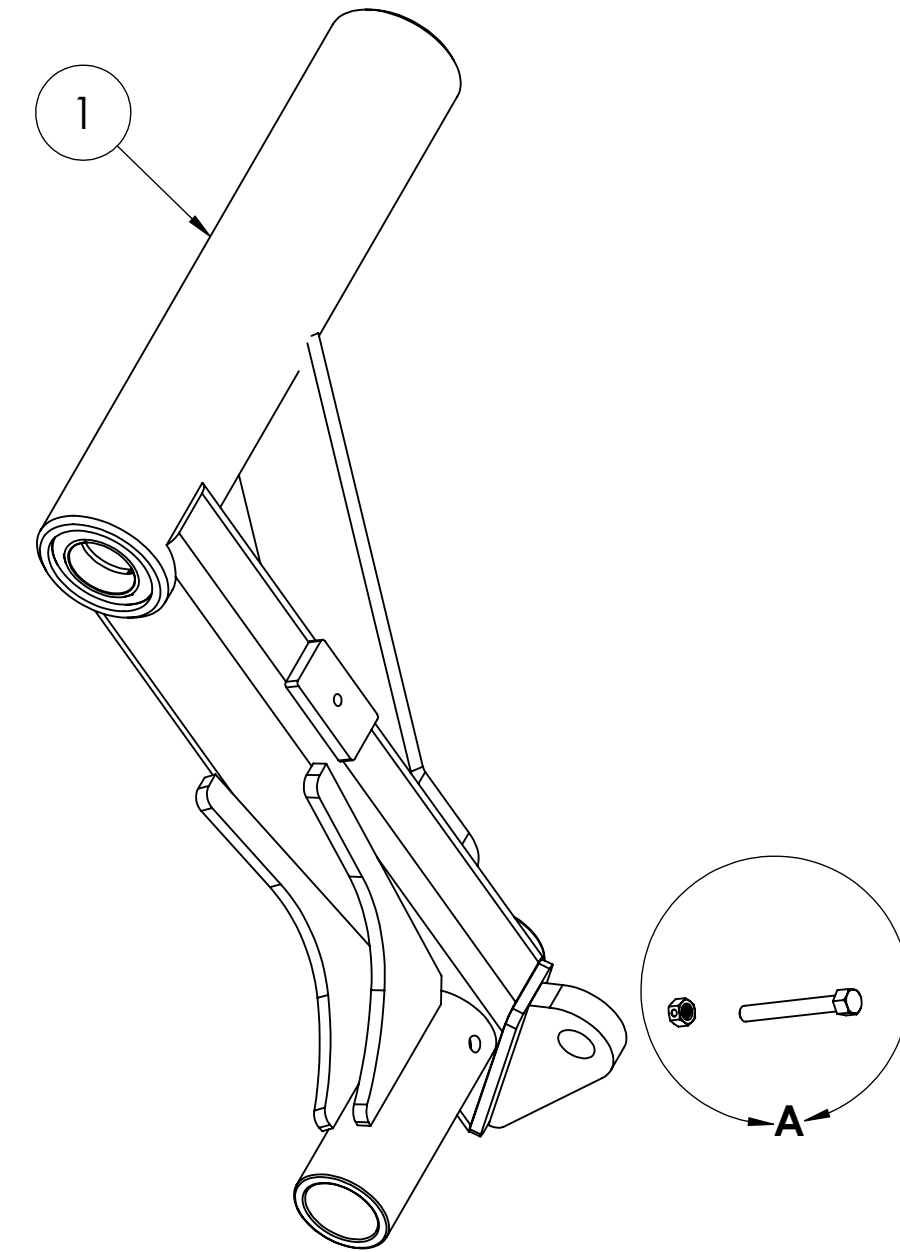
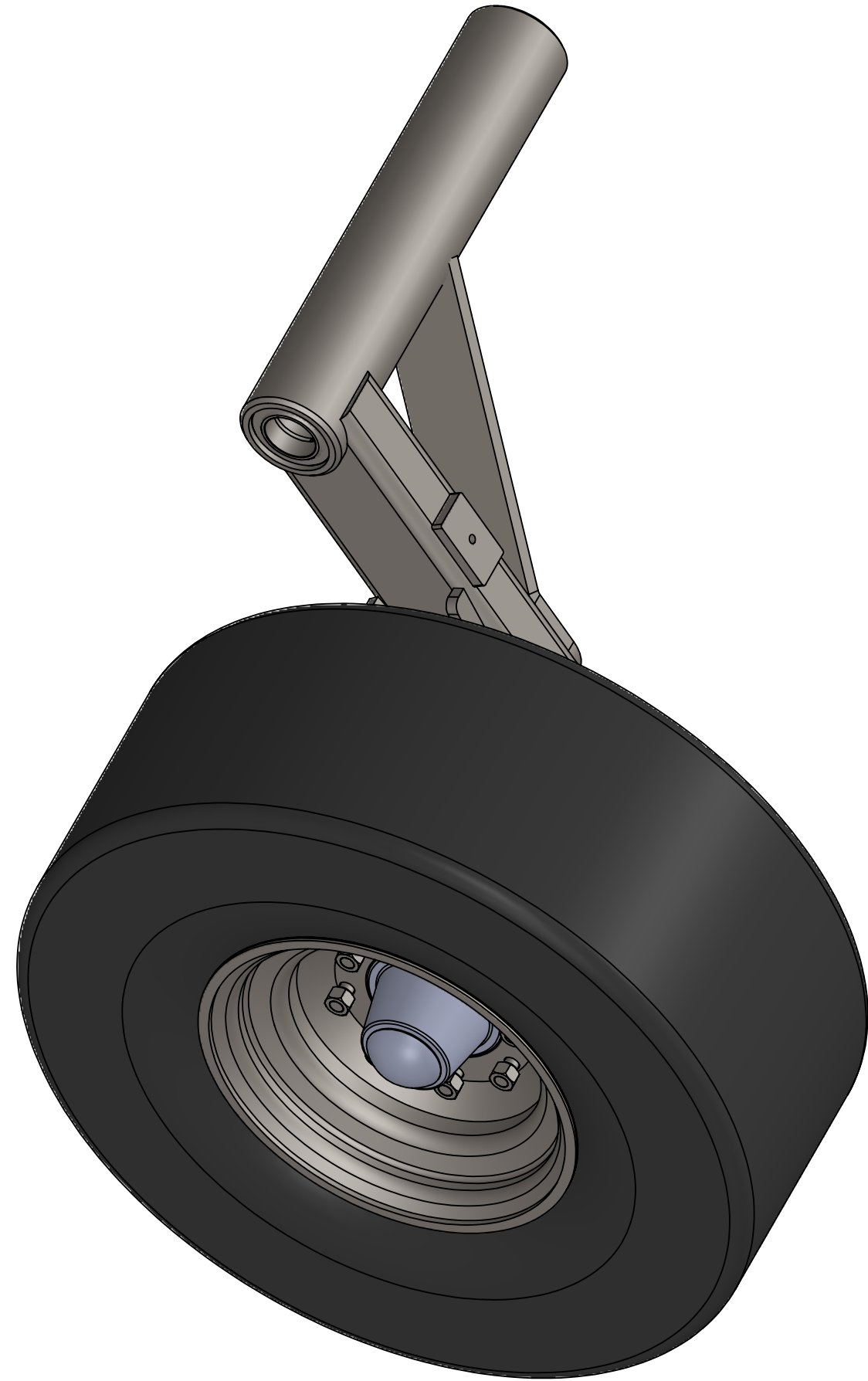

ITEM NO.	PART NUMBER	DESCRIPTION	QTY.
1	MM7000060	6' Series III Rockshaft	1
2	150120	1/2" x 4" BOLT	1
3	150419	1/2" NC Hex Top Lock Nut	1
4	MM8000001	8 BOLT HUB & SPINDLE ASSY.	1
5	MM8000307	320/70/R15 TIRE AND RIM ASSY	1

LEFT ROCKSHAFT MM8000200

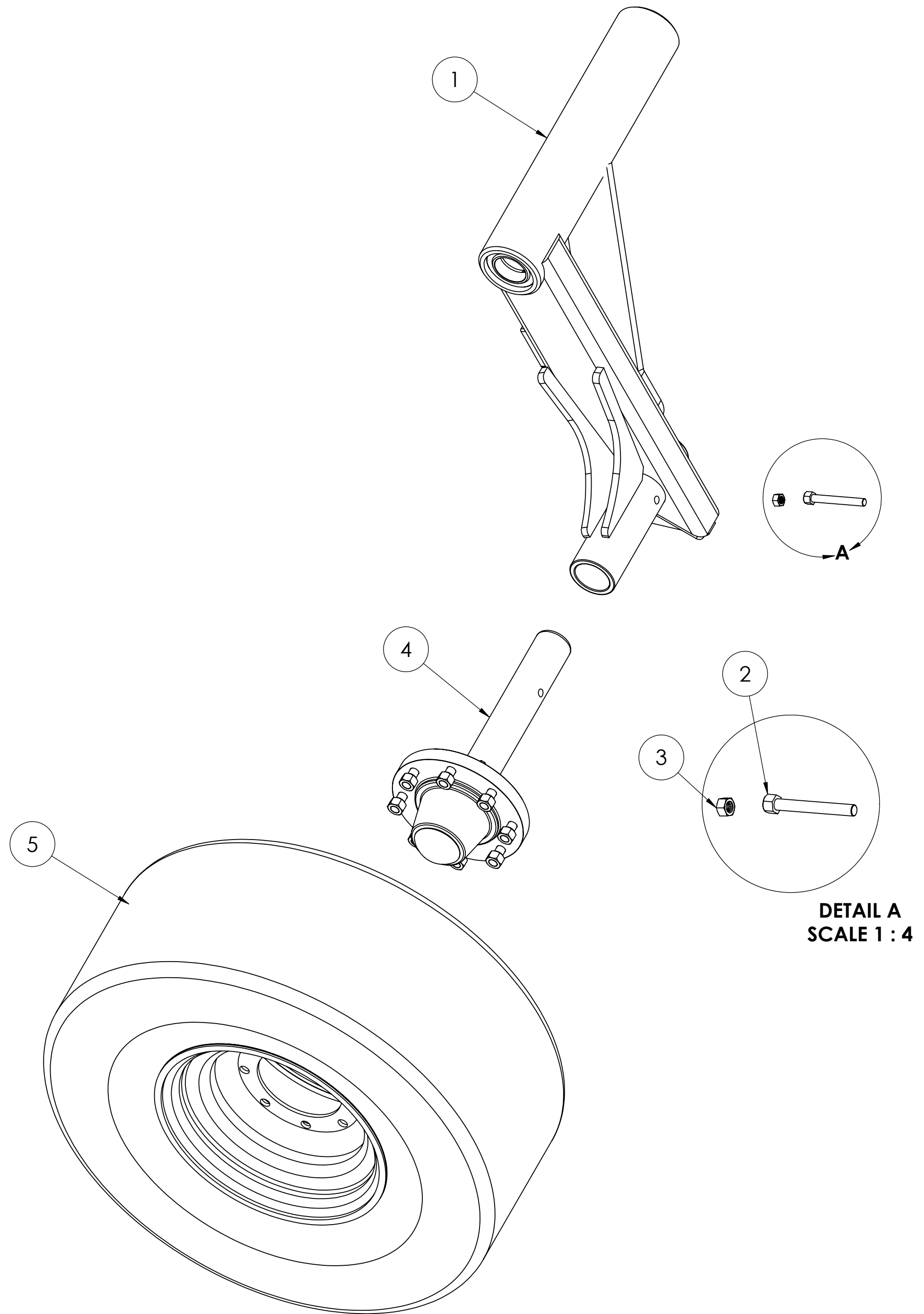

DETAIL A
SCALE 1 : 4

ITEM NO.	PART NUMBER	DESCRIPTION	QTY.
1	MM7000061	6' Series III Right Rockshaft	1
2	150120	1/2" x 4" BOLT	1
3	150419	1/2" NC Hex Top Lock Nut	1
4	MM8000001	8 BOLT HUB & SPINDLE ASSY.	1
5	MM8000307	320/70/R15 TIRE AND RIM ASSY	1

RIGHT ROCKSHAFT MM800201

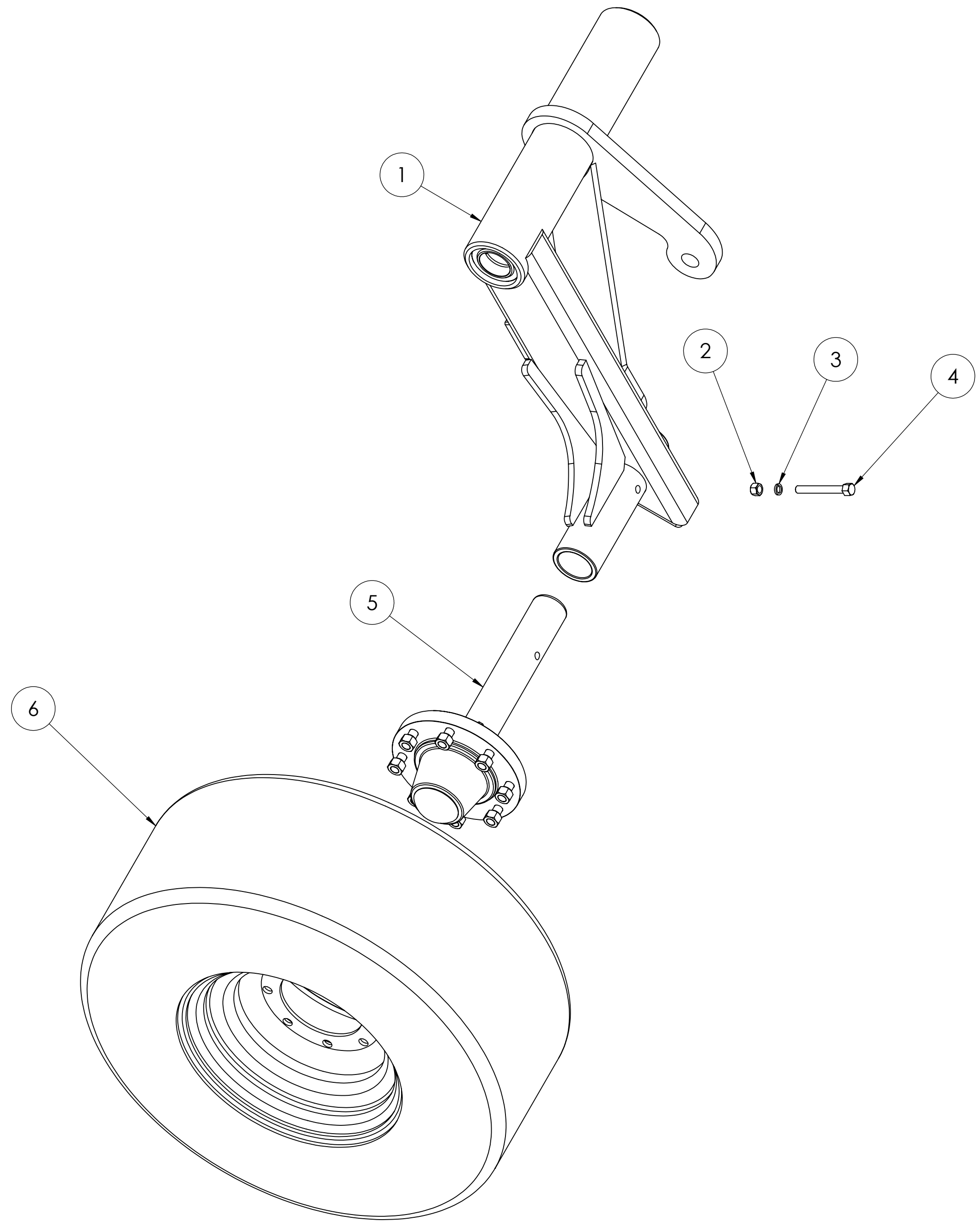

ITEM NO.	PART NUMBER	DESCRIPTION	QTY.
1	MM7000362	6" ROCKSHAFT LEFT SIDE	1
2	150031	1/2" NUT	1
3	150030	1/2" LOCKWASHER	1
4	150120	1/2" x 4" BOLT	1
5	MM8000001	8 BOLT HUB & SPINDLE ASSEMBLY	1
6	MM8000307	TIRE & WHEEL ASSEMBLY 320/70-R15	1

AUXILLARY ROCKSHAFT MM8000502

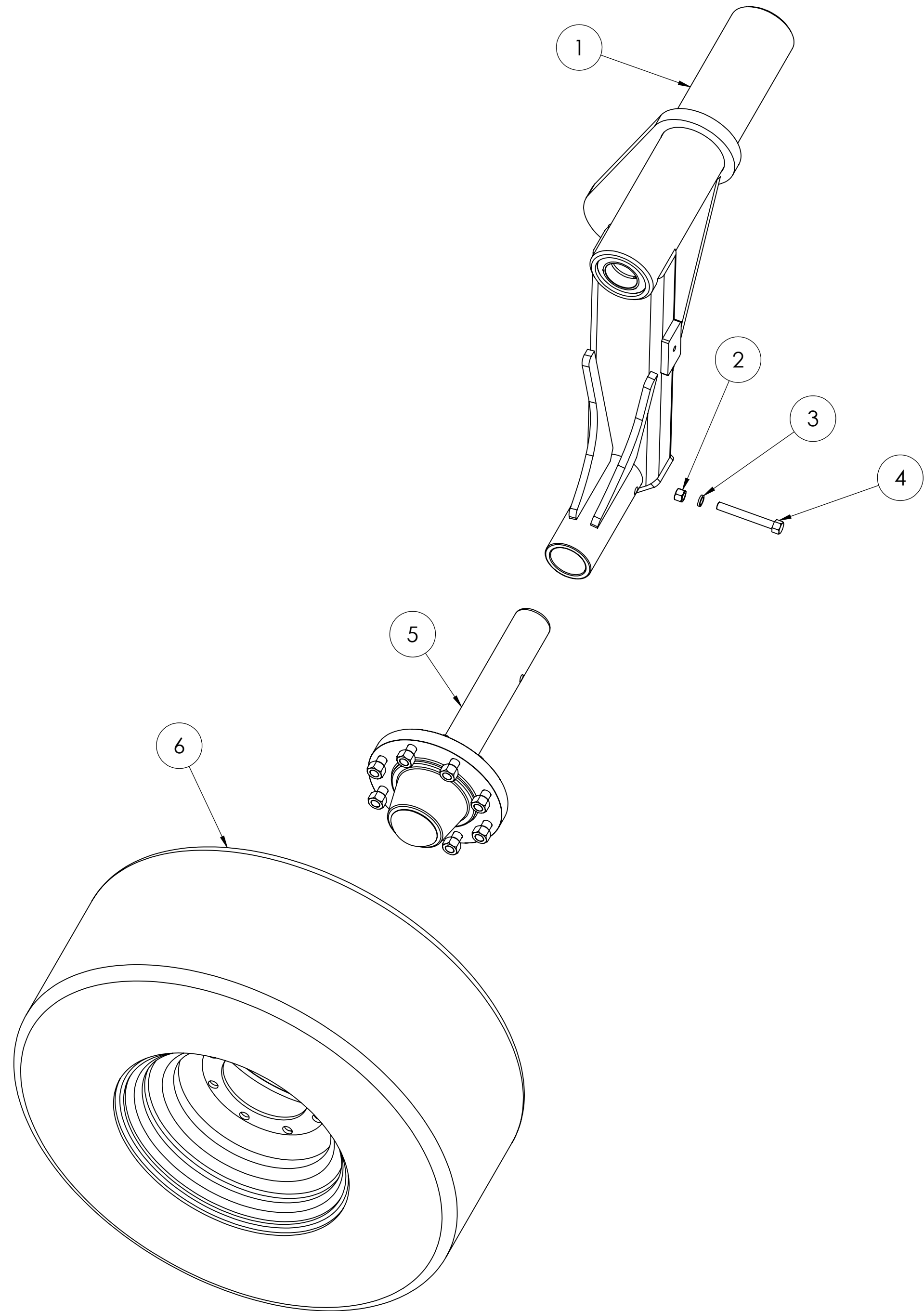
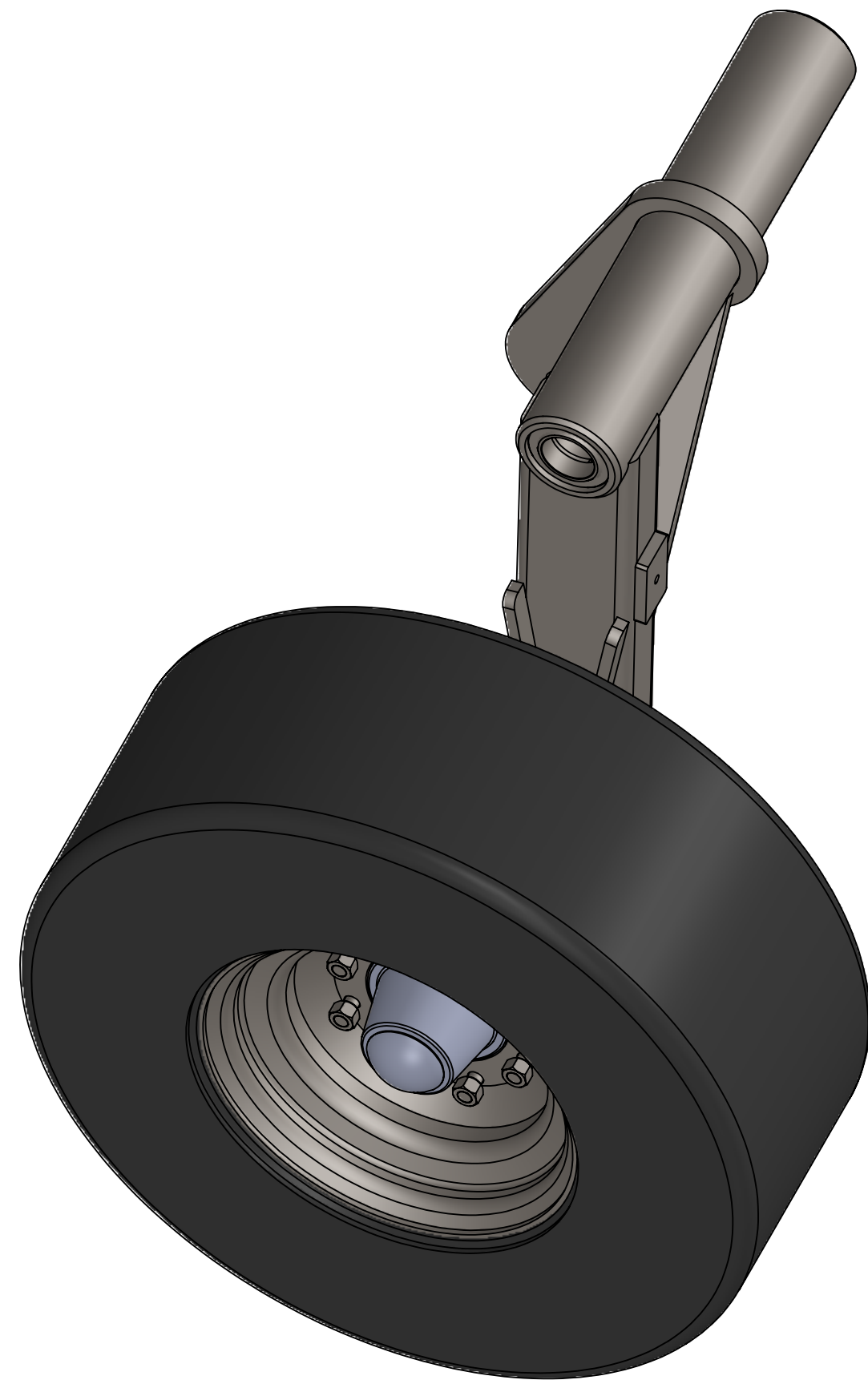

ITEM NO.	PART NUMBER	DESCRIPTION	QTY.
1	MM7000363	11x6 series II Left Auxillary Transport Rockshaft Assembly	1
2	150031	1/2" NUT	1
3	150030	1/2" LOCKWASHER	1
4	150120	1/2" x 4" BOLT	1
5	MM8000001	8 BOLT HUB & SPINDLE ASSY.	1
6	MM8000307	TIRE & WHEEL ASSEMBLY 320/70-R15	1

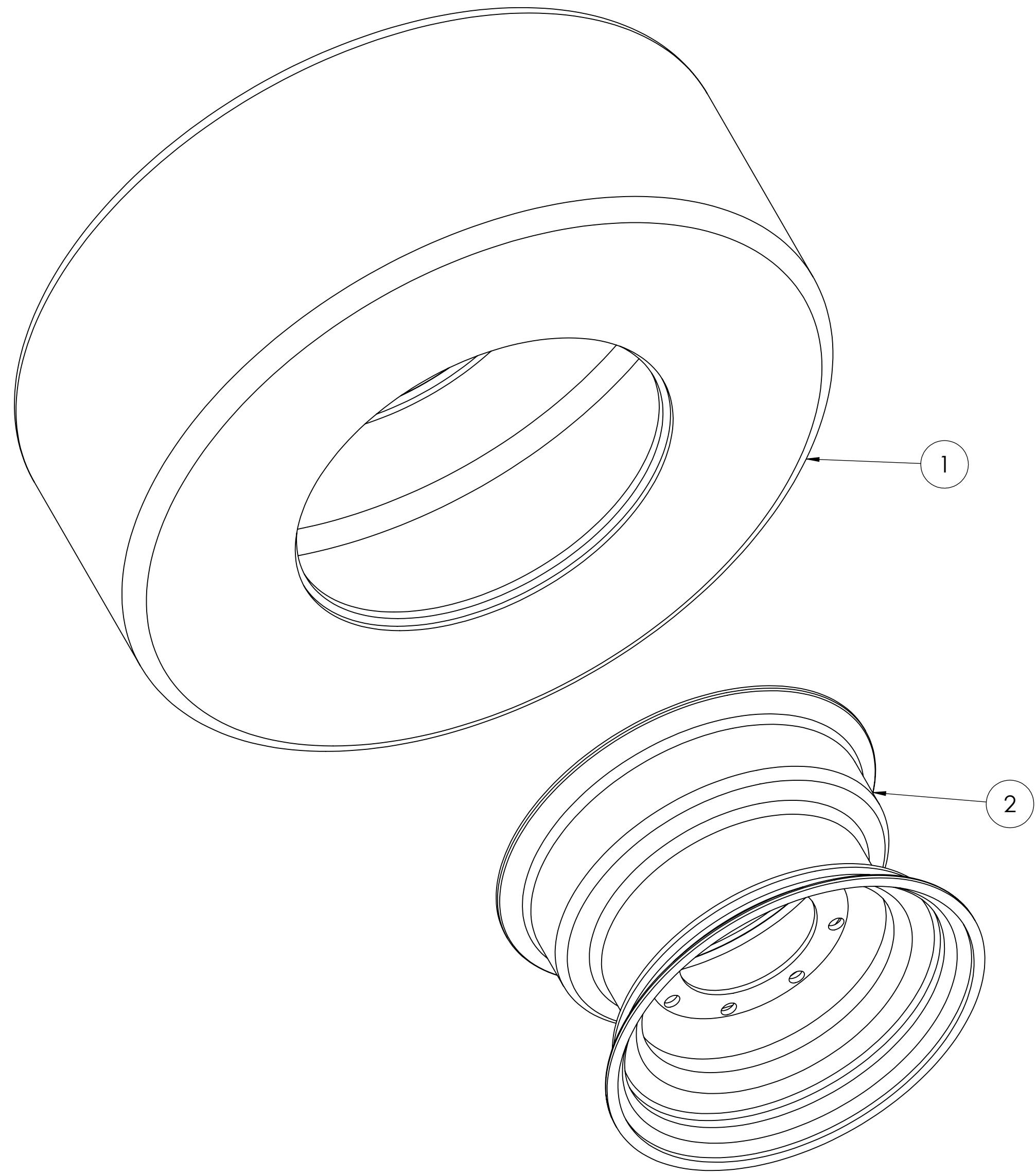
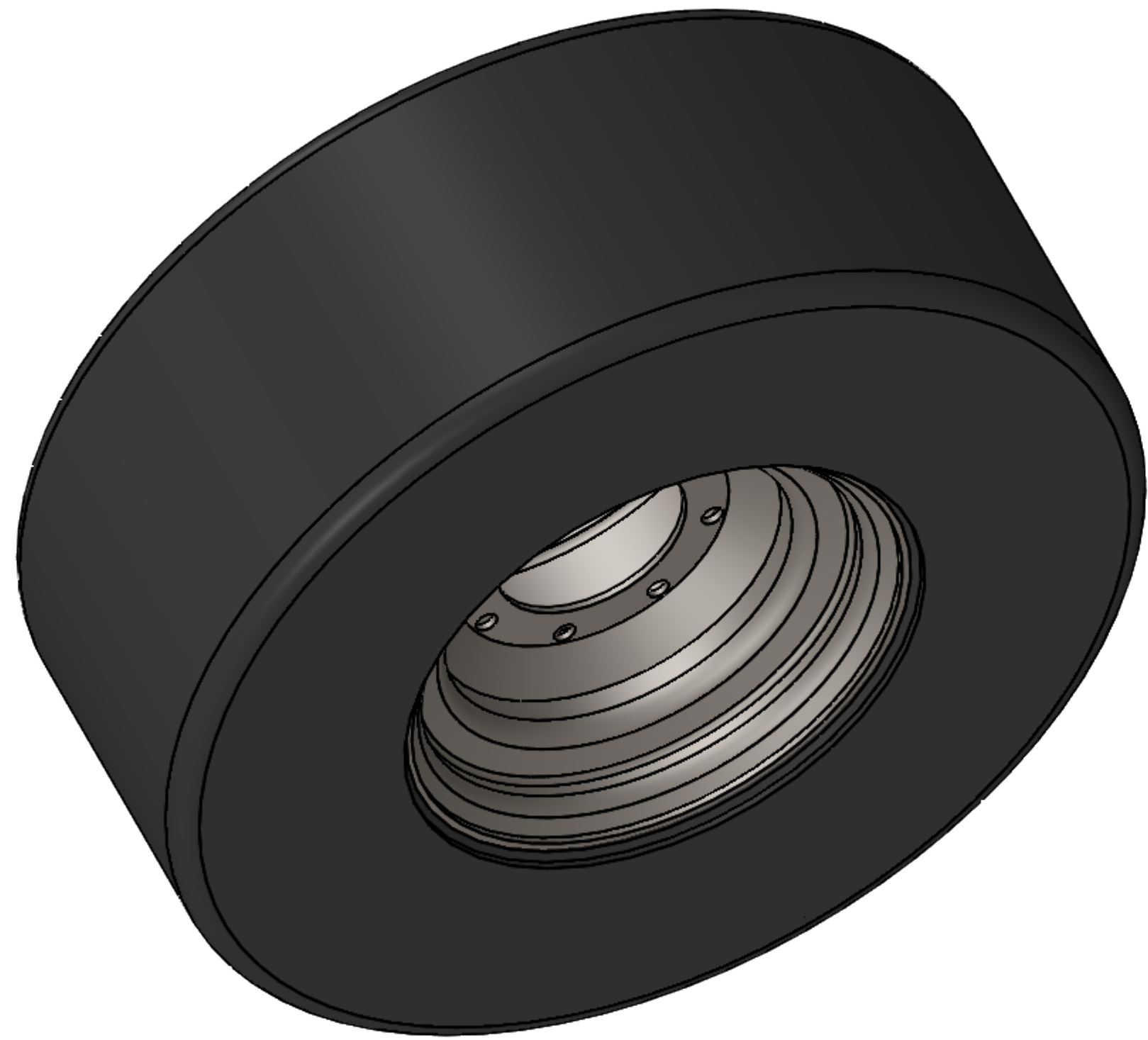

ITEM NO.	PART NUMBER	DESCRIPTION	QTY.
1	MM3500088	TIRE 280R15	1
2	MM3500089	RIM 15-10 8 BOLT	1

TIRE AND WHEEL ASSEMBLY MM8000306

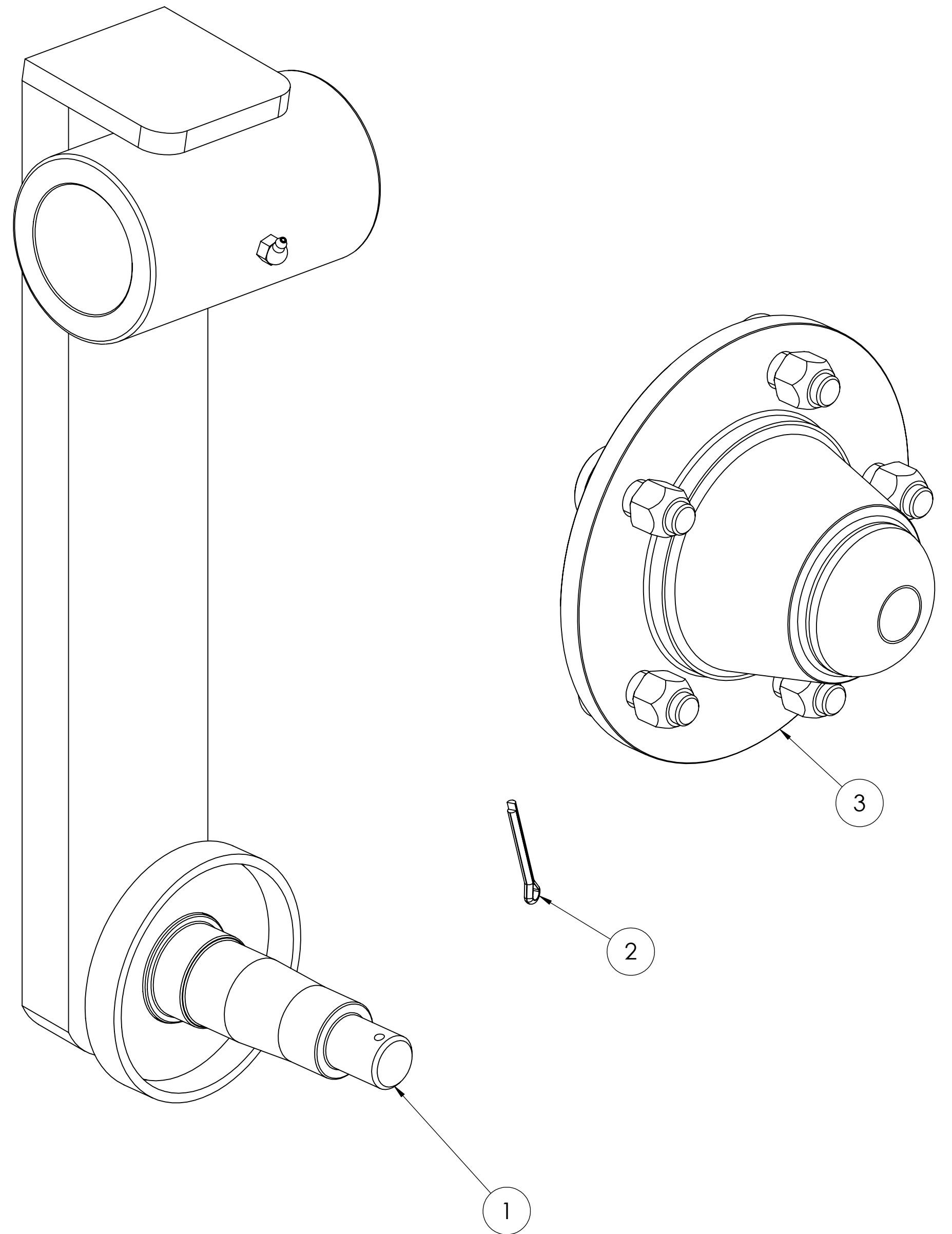
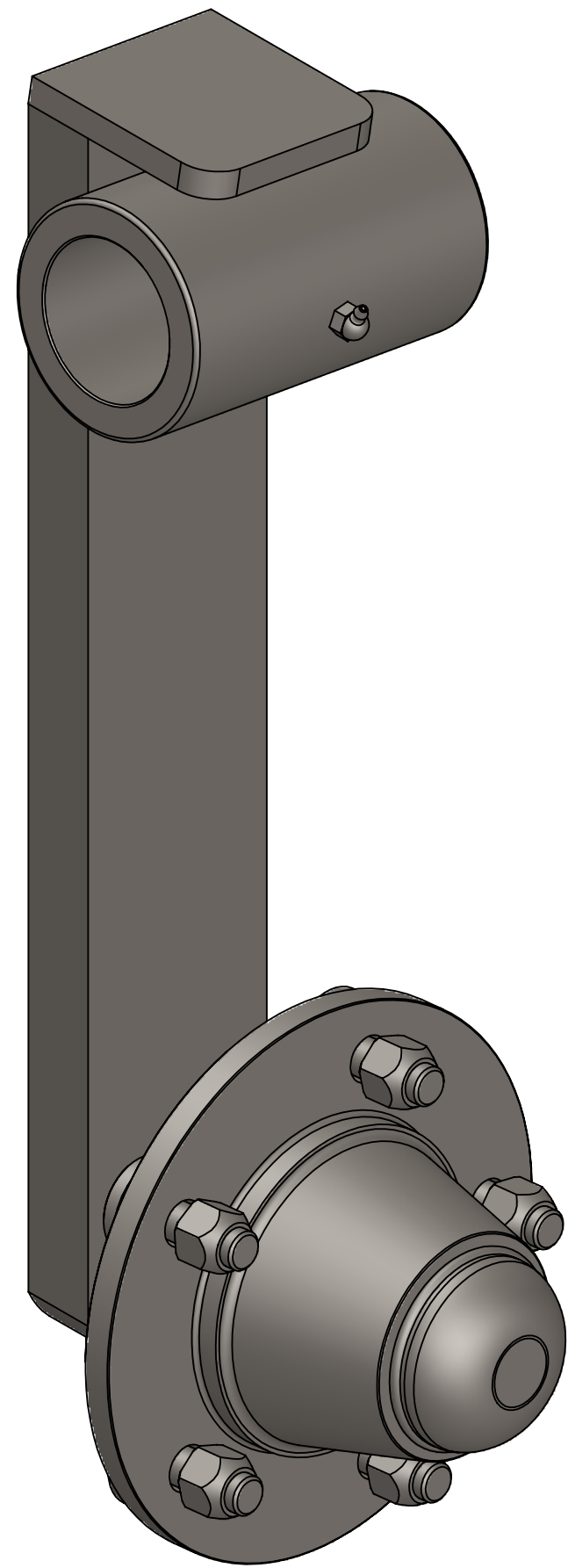

ITEM NO.	PART NUMBER	DESCRIPTION	QTY.
1	MM7000800	COULTER ARM ASSY.	1
2	150022	COTTER PIN	1
3	MM7020952	5 BOLT HUB ASSY.	1

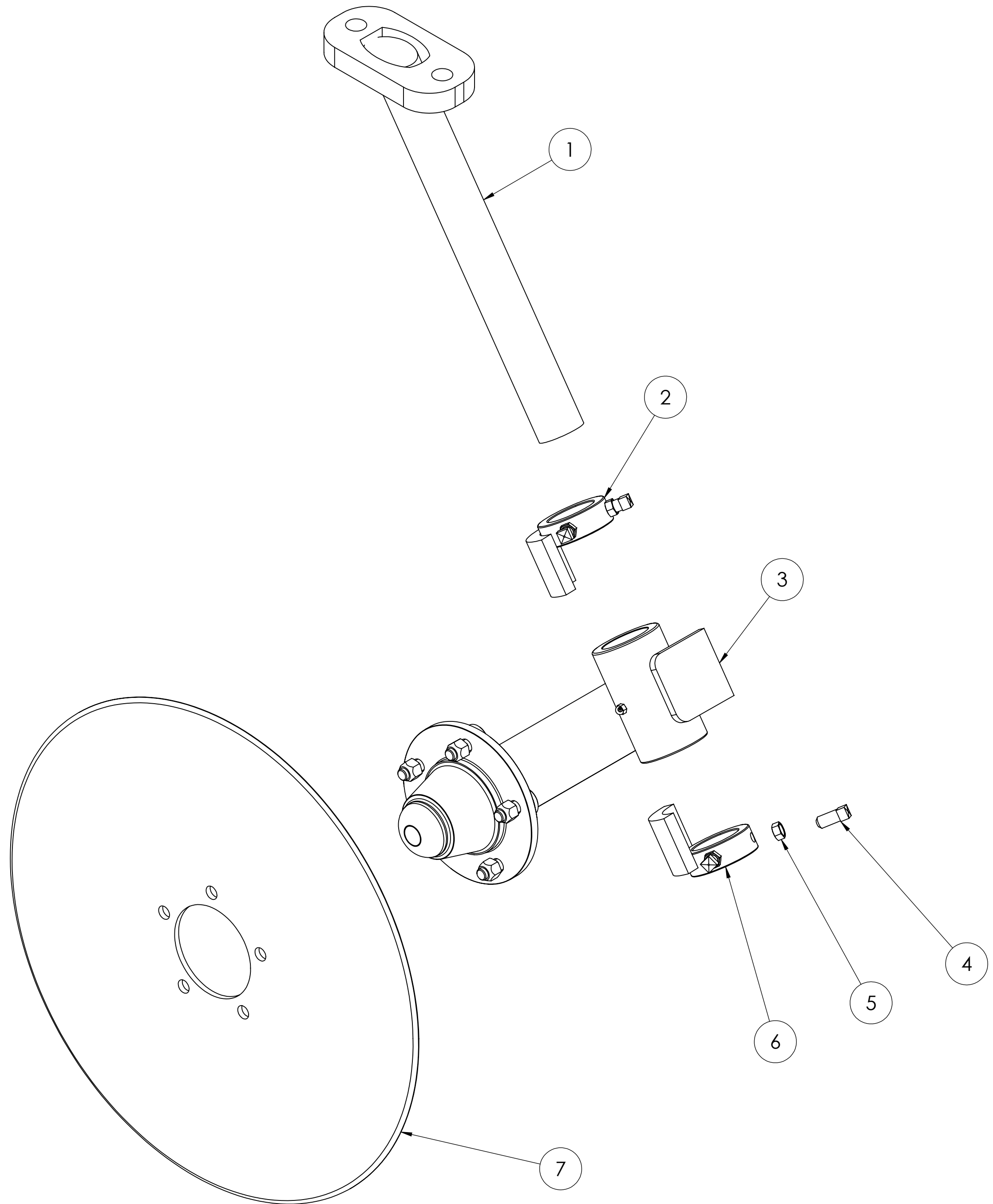
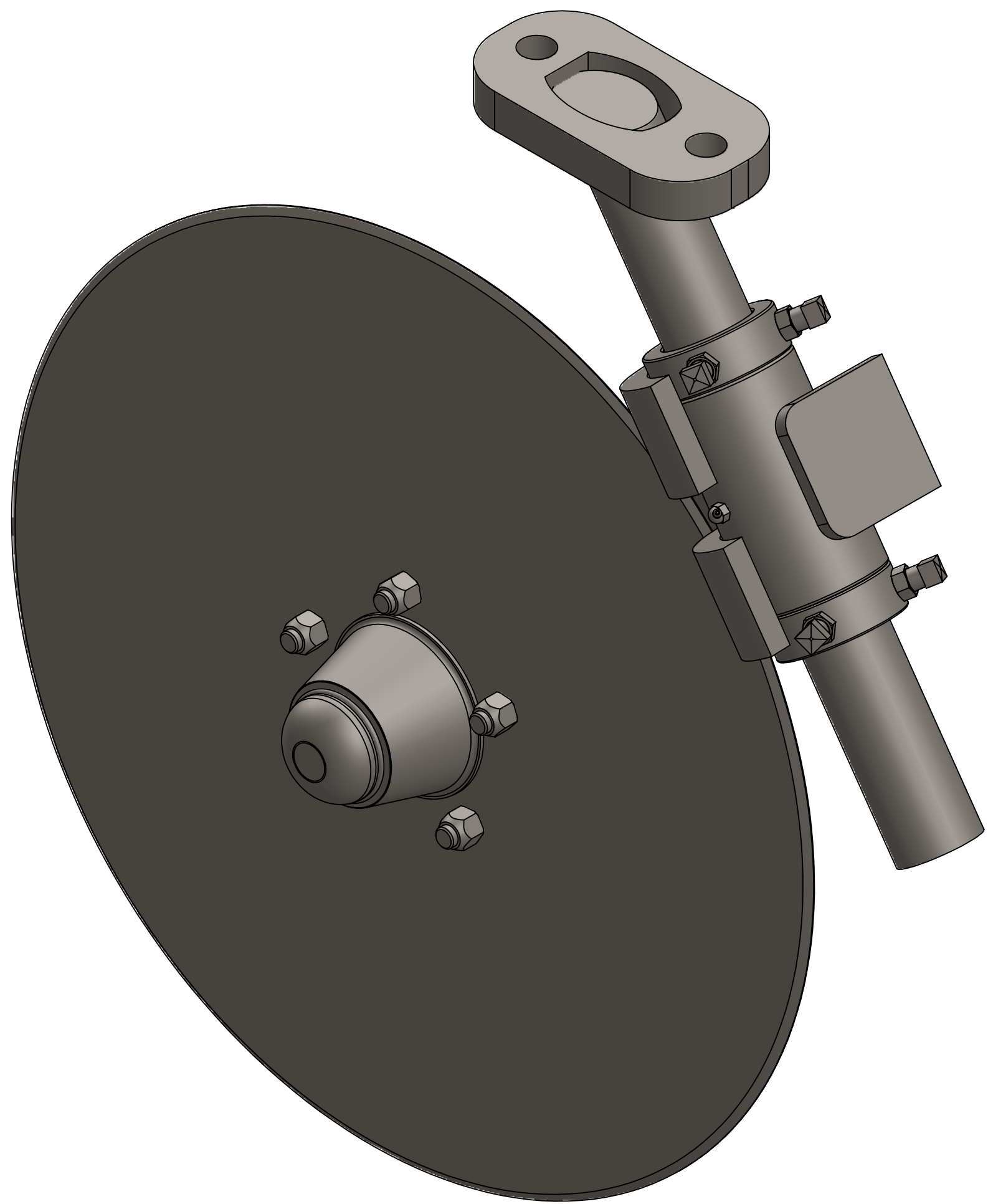

ITEM NO.	PART NUMBER	DESCRIPTION	QTY.
1	MM7000115	Series III Colter Shaft Complete	1
2	MM7000340	Series III Colter Lock Collar Complete	1
3	MM8000300	Series III Complete Colter Arm Assembly	1
4	150044	1/2" x 1" SET SCREW	4
5	150045	0.5 Jam Nut	4
6	MM7000341	Series III Colter Lock Collar Complete	1
7	320033	22-1/2" COULTER BLADE	1

NON-SWIVEL COULTER ARM ASSYEMBLY MM9000050

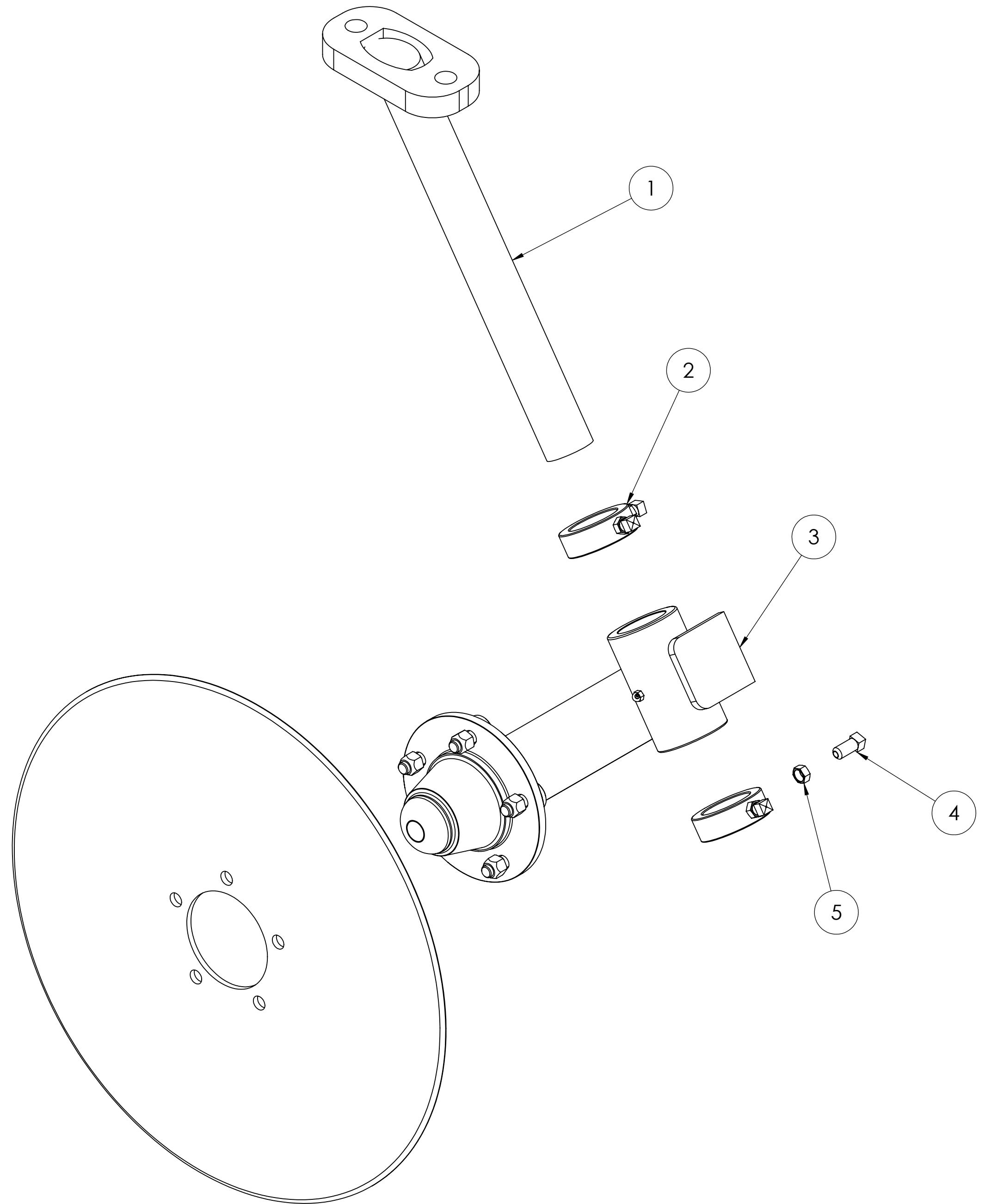
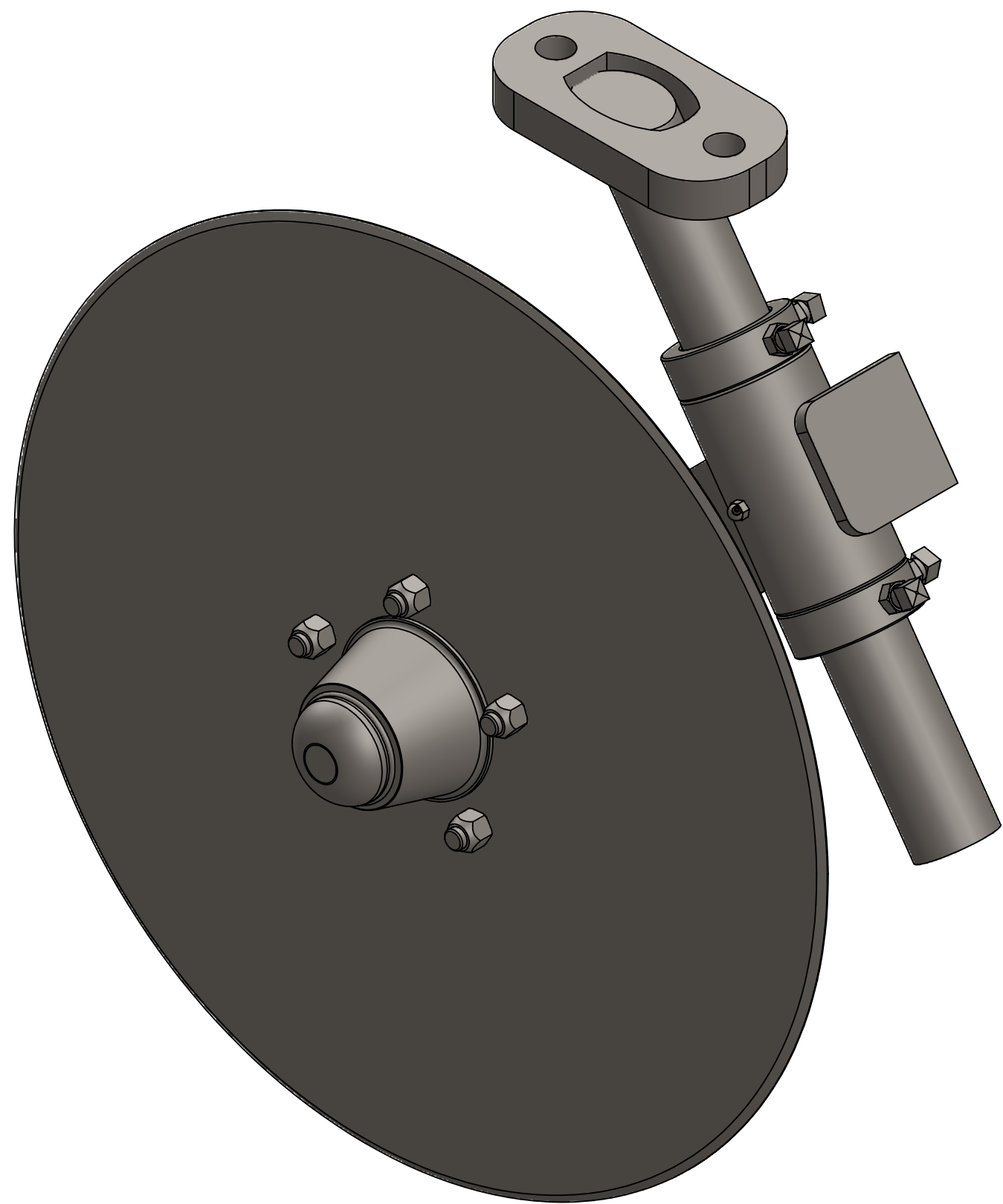

ITEM NO.	PART NUMBER	DESCRIPTION	QTY.
1	MM7000115	Series III Colter Shaft Complete	1
2	MM7000339	Series III Colter Lock Collar	2
3	MM8000300	Series III Complete Colter Arm Assembly	1
4	150044	1/2" x 1" SET SCREW	4
5	150045	.5 Jam Nut	4
6	320033	22-1/2" COULTER BLADE	1

SWIVEL COULTER ARM ASSEMBLY MM9000051

9-6' SIII Hydraulic Routings and Hardware



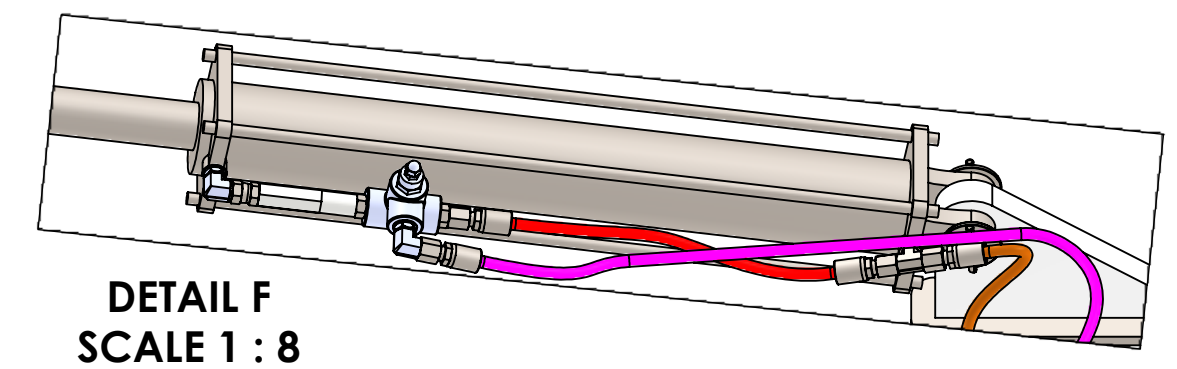
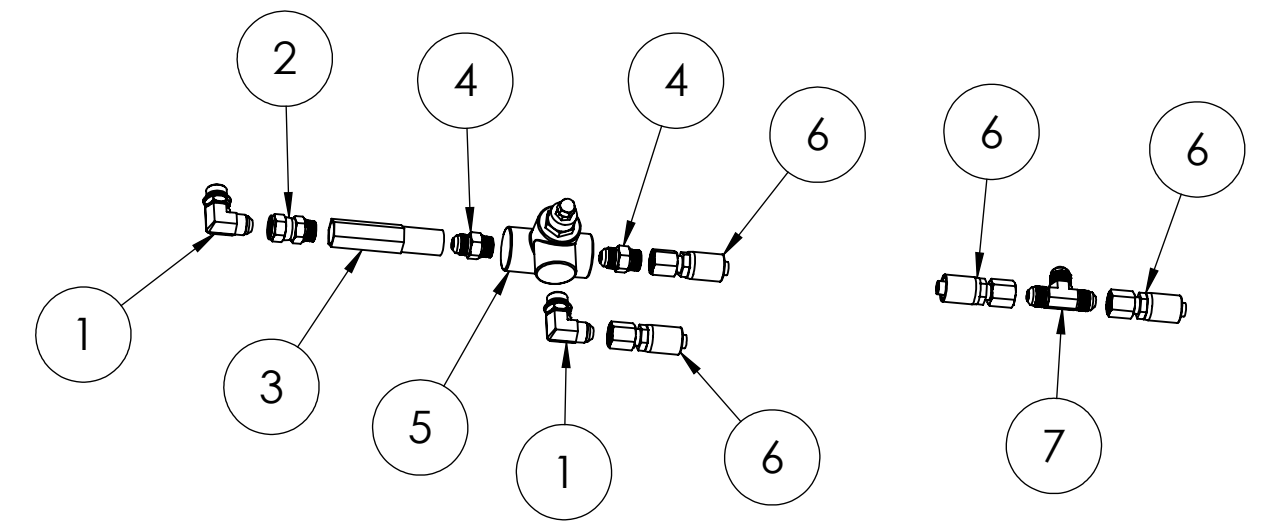
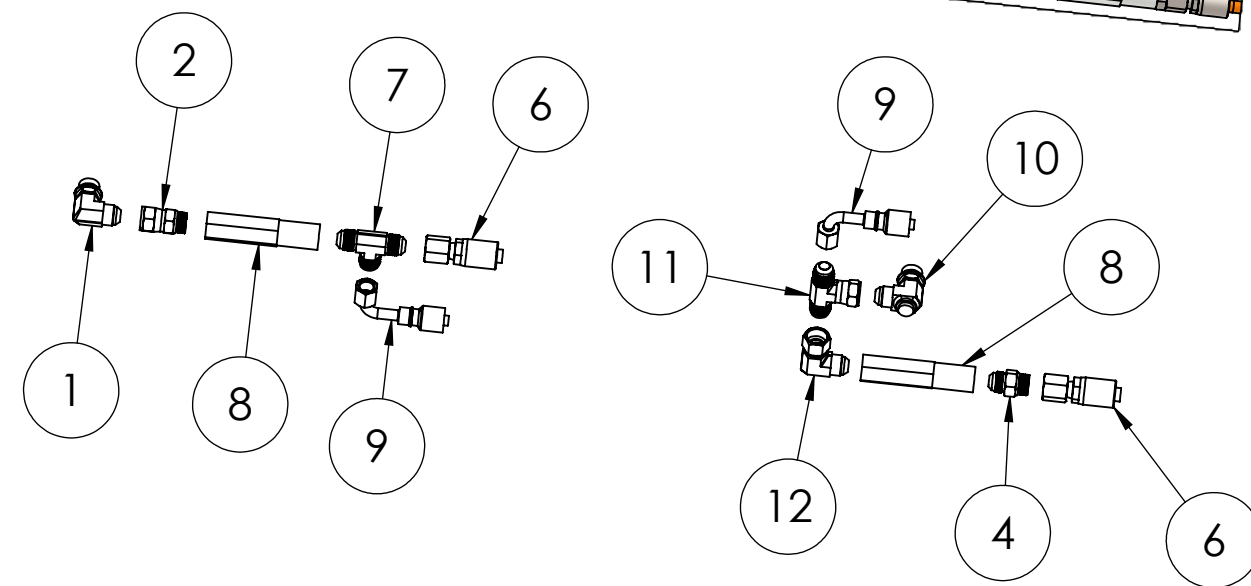
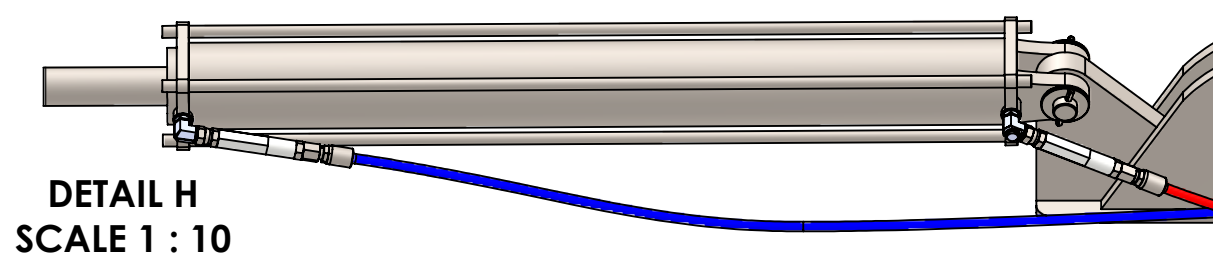
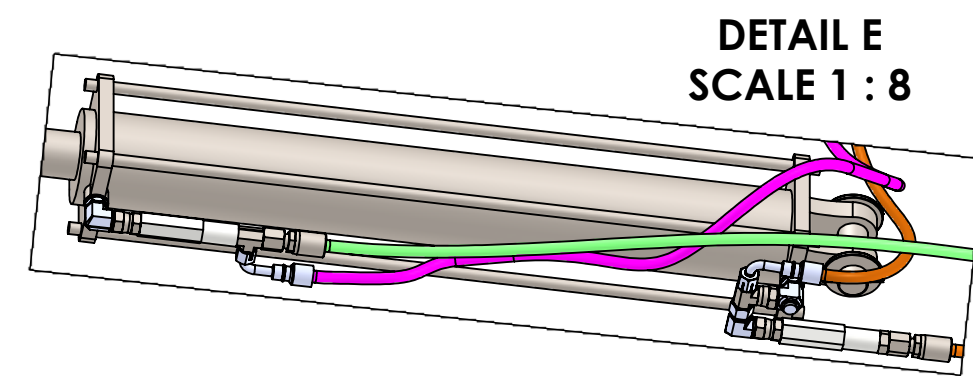
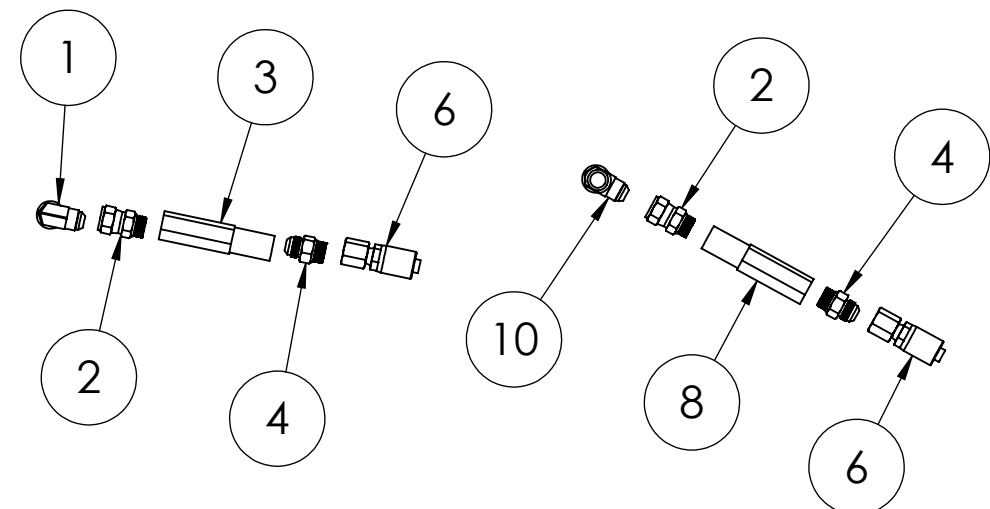
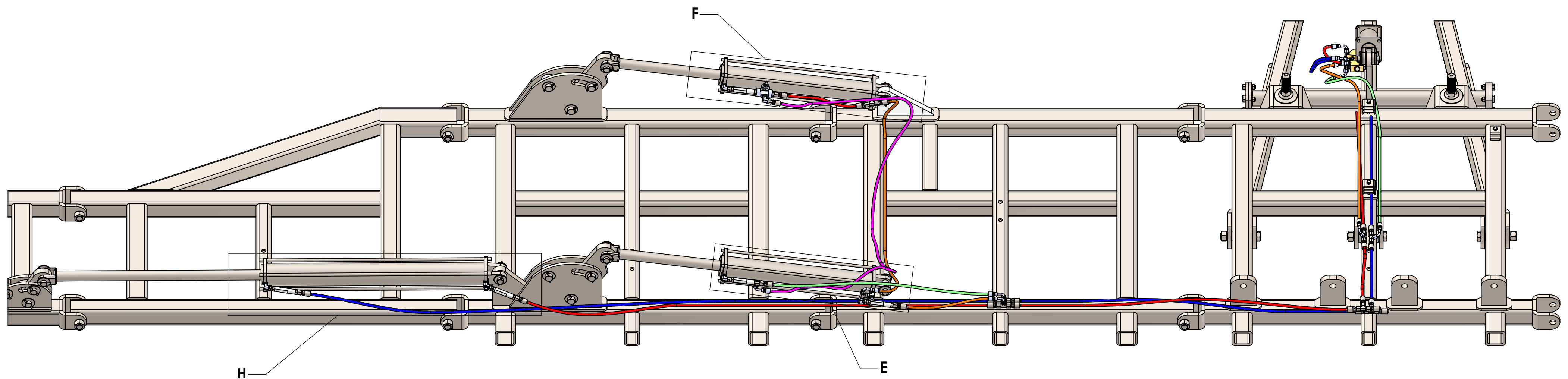

ITEM NO.	PART NUMBER	DESCRIPTION	QTY.
1	8MB-8MJ90	MALE O-RING BOSS TO MALE JIC 37° FLARE (90° BEND)	4
2	8MB-8FJX	MALE O-RING BOSS TO FEMALE JIC 37° FLARE SWIVEL	4
3	MM3300269	1500 PSI VONBERG VALVE (49040-1500)	2
4	8MB-8MJ	MALE O-RING BOSS TO MALE JIC 37° FLARE	5
5	330124	HYDRAULIC VALVE, 3/4-16 FEMALE O-RING BOSS	1
6	8G-8FJX	1/2 HOSE X 3/4 - 16 FEMALE JIC SWIVEL	8
7	8MJT	3-4 - 16 MALE JIC TEE	2
8	MM3300318	800 PSI VONBERG VALVE (49040-800)	3
9	8G-8FJX90S	90° Bent Tube Female JIC 37° Swivel Megacrimp G25 Coupling	2
10	HY9S6J8-08	3/4"-16 MALE O-RING SPECIAL 90° SWIVEL FIT	2
11	8FJX-8MJT	FEMALE JIC 37° FLARE TO MALE JIC 37° FLARE TEE	1
12	8MJ-8FJ90	MALE JIC 37° FLARE TO FEMALE JIC 37° (90°)	1

9-6' SIII FOLDING CYLINDER HARDWARE

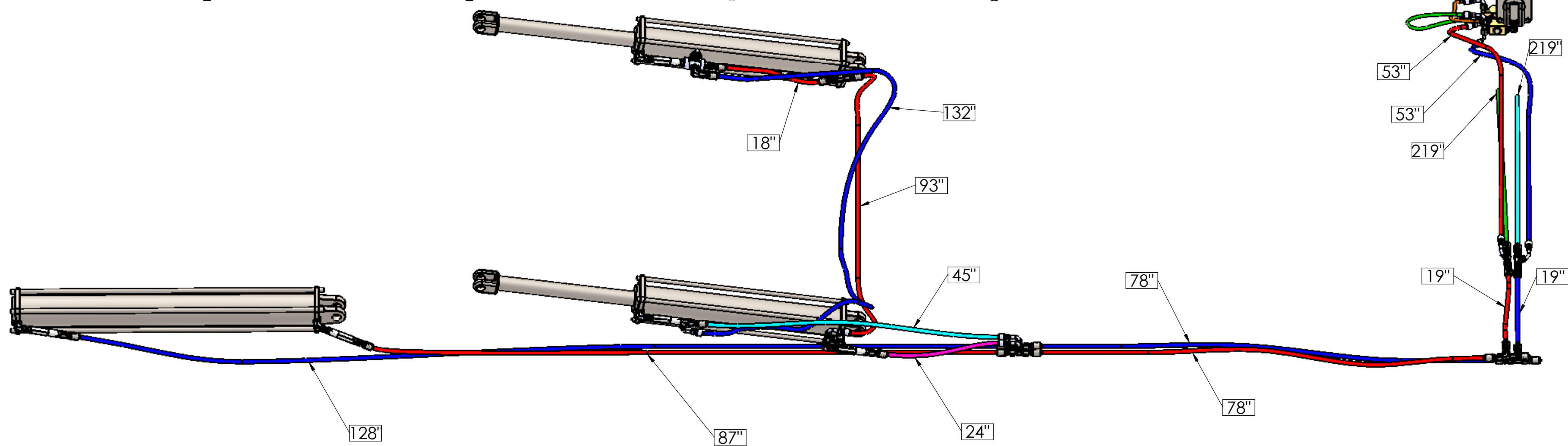
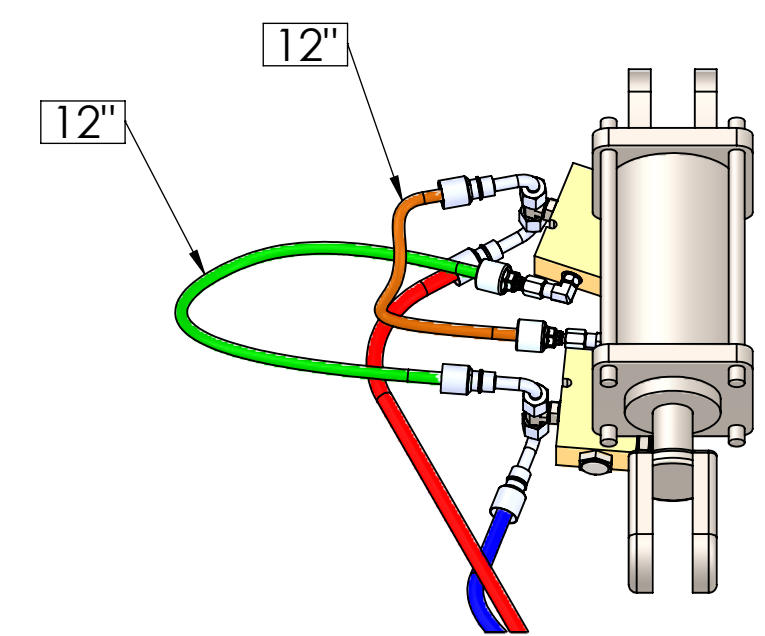
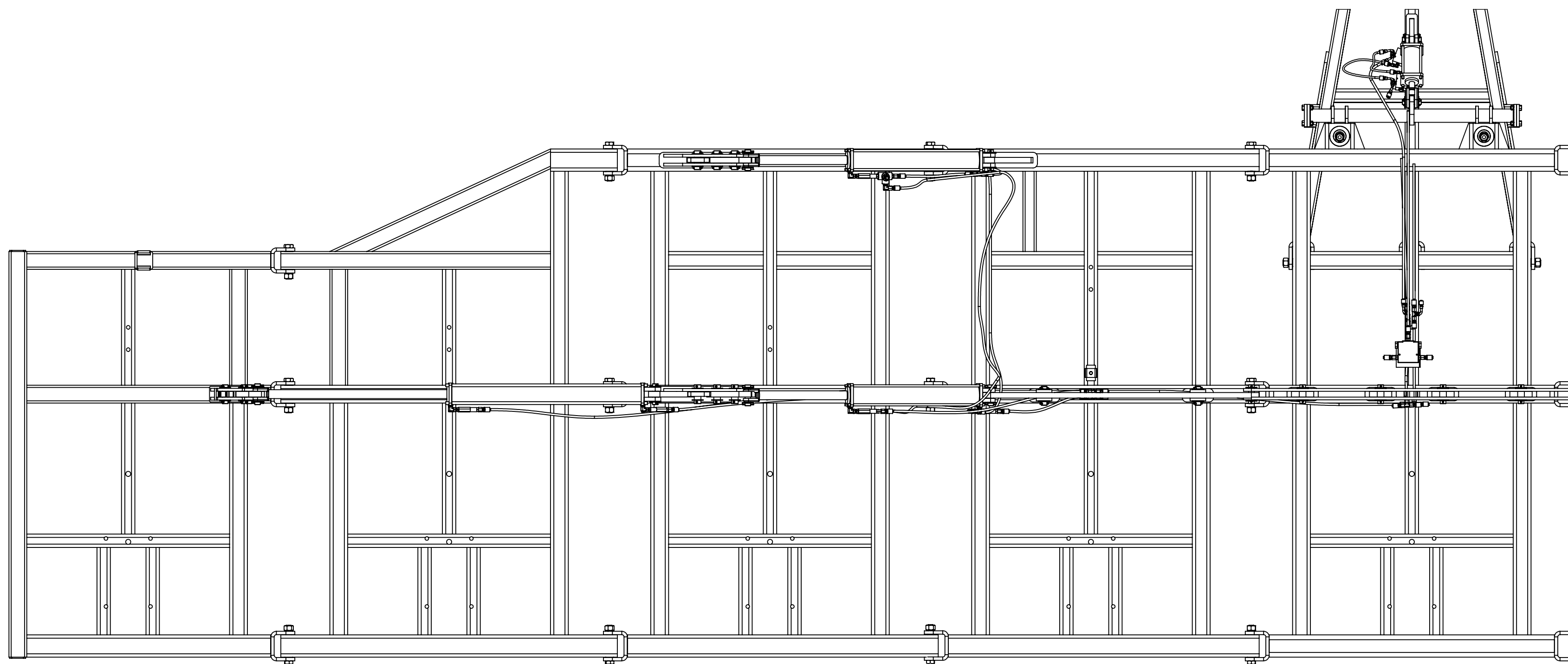

9-6' SIII FOLDING HYDRAULIC ROUTING AND LENGTHS

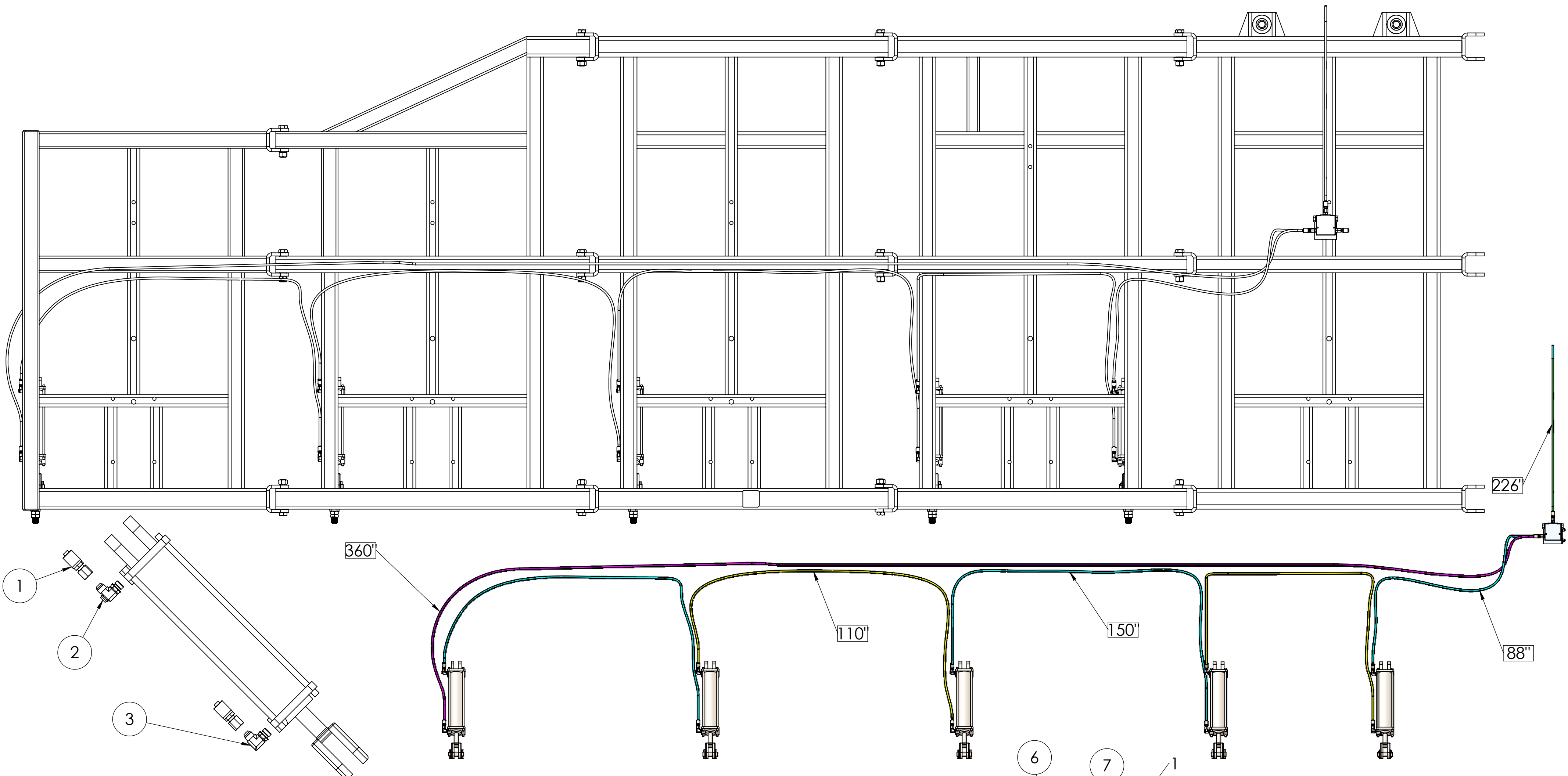

ITEM NO.	PART NUMBER	DESCRIPTION	QTY.
1	8G-8FJX	1/2 HOSE X 3/4 - 16 FEMALE JIC SWIVEL	3
2	HY9S6J8-08	3/4"-16 MALE O-RING SPECIAL 90° SWIVEL FIT	1
3	8MB-8MJ90	MALE O-RING BOSS TO MALE JIC 37° FLARE BENT (90°)	1
4	MM3500083	HYDRAULIC DIVIDER VALVE	1
5	8MB-8MJ	8MB-8MJ	1
6	150003	1/2" FLANGE NUT	2
7	150001	1/4" X 4-1/2" BOLT	2
8	MM5000347	MM3500083 HYDRAULIC VALVE STAND	1
9	MM1500390	3/8" x 4" x 4-1/2" U-BOLT	2
10	150004	3/8 SERRATED FLANGE NUT	4

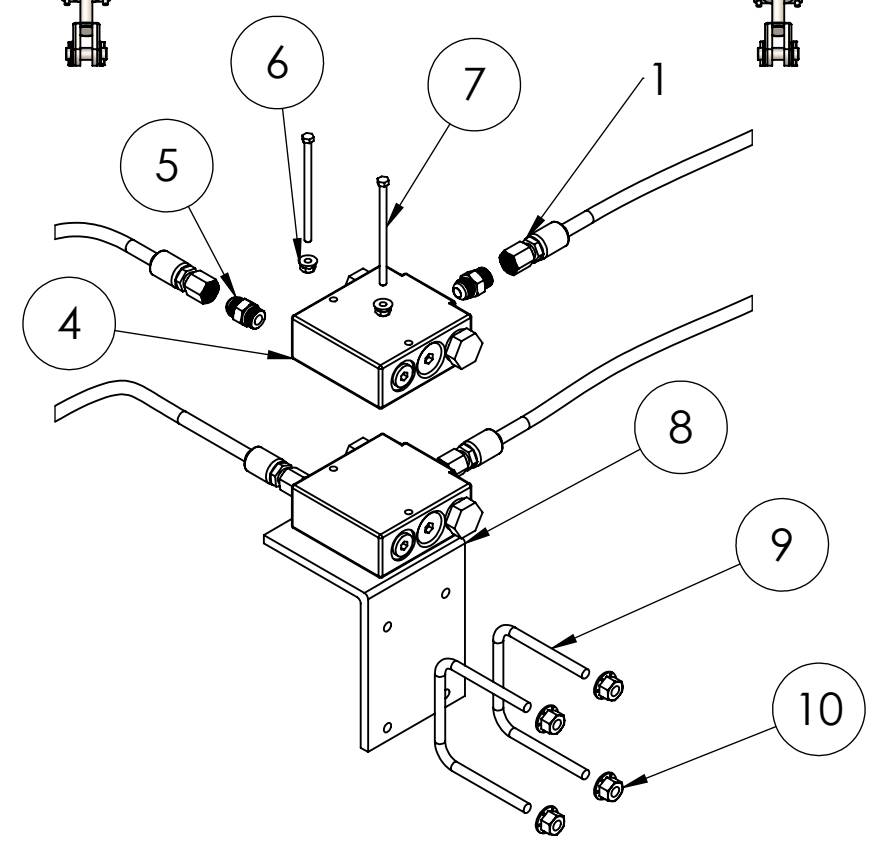

9-6' DEPTH CYLINDER HOSES, HARDWARE AND LENGTHS

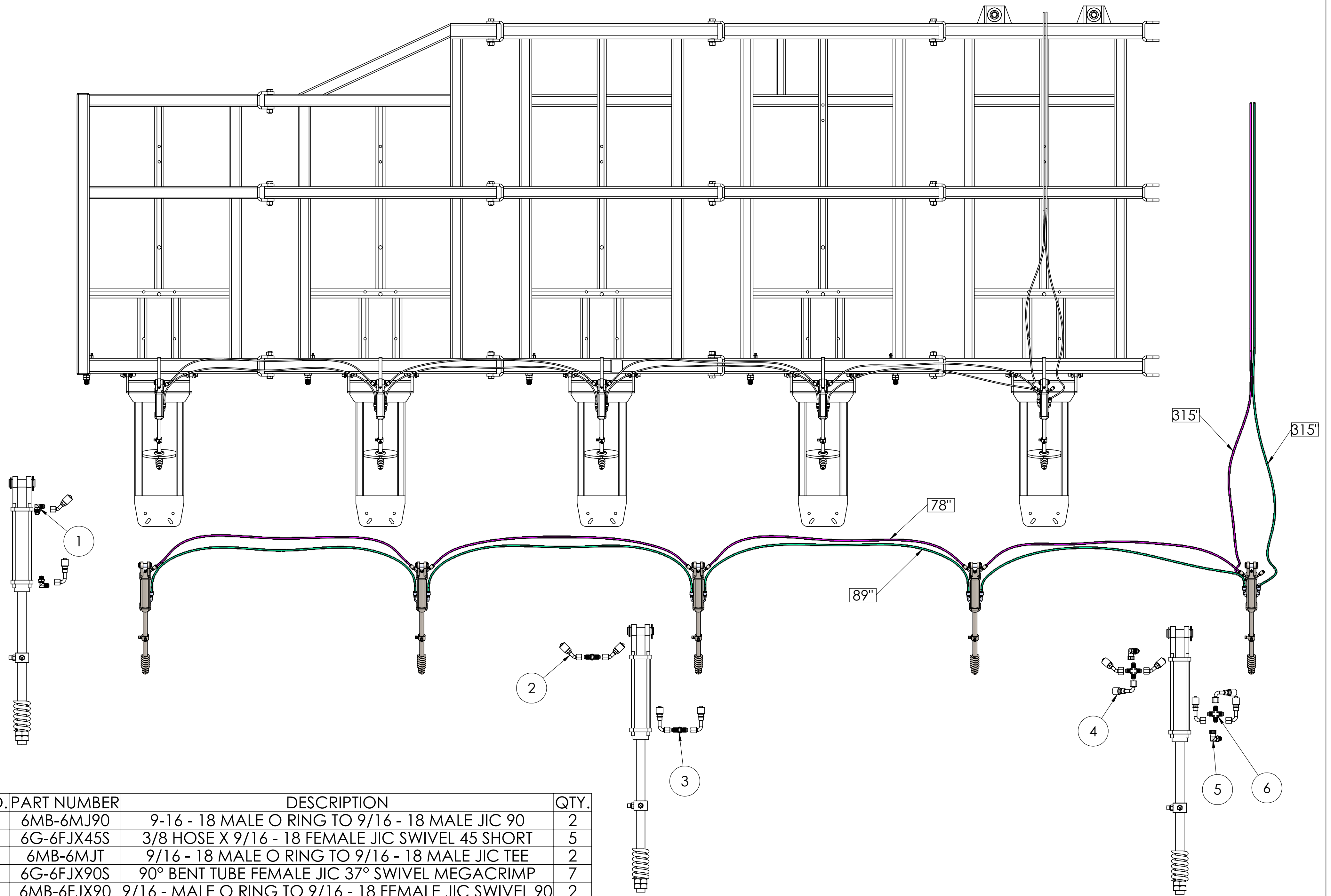

ITEM NO.	PART NUMBER	DESCRIPTION	QTY.
1	6MB-6MJ90	9-16 - 18 MALE O RING TO 9/16 - 18 MALE JIC 90	2
2	6G-6FJX45S	3/8 HOSE X 9/16 - 18 FEMALE JIC SWIVEL 45 SHORT	5
3	6MB-6MJT	9/16 - 18 MALE O RING TO 9/16 - 18 MALE JIC TEE	2
4	6G-6FJX90S	90° BENT TUBE FEMALE JIC 37° SWIVEL MEGACRIMP	7
5	6MB-6FJX90	9/16 - MALE O RING TO 9/16 - 18 FEMALE JIC SWIVEL 90	2
6	6MJ-CROSS	9/16 - 18 MALE JIC CROSS	2

9-6' SIII PICKER HYDRAULIC ROUTING, HARDWARE AND LENGTHS

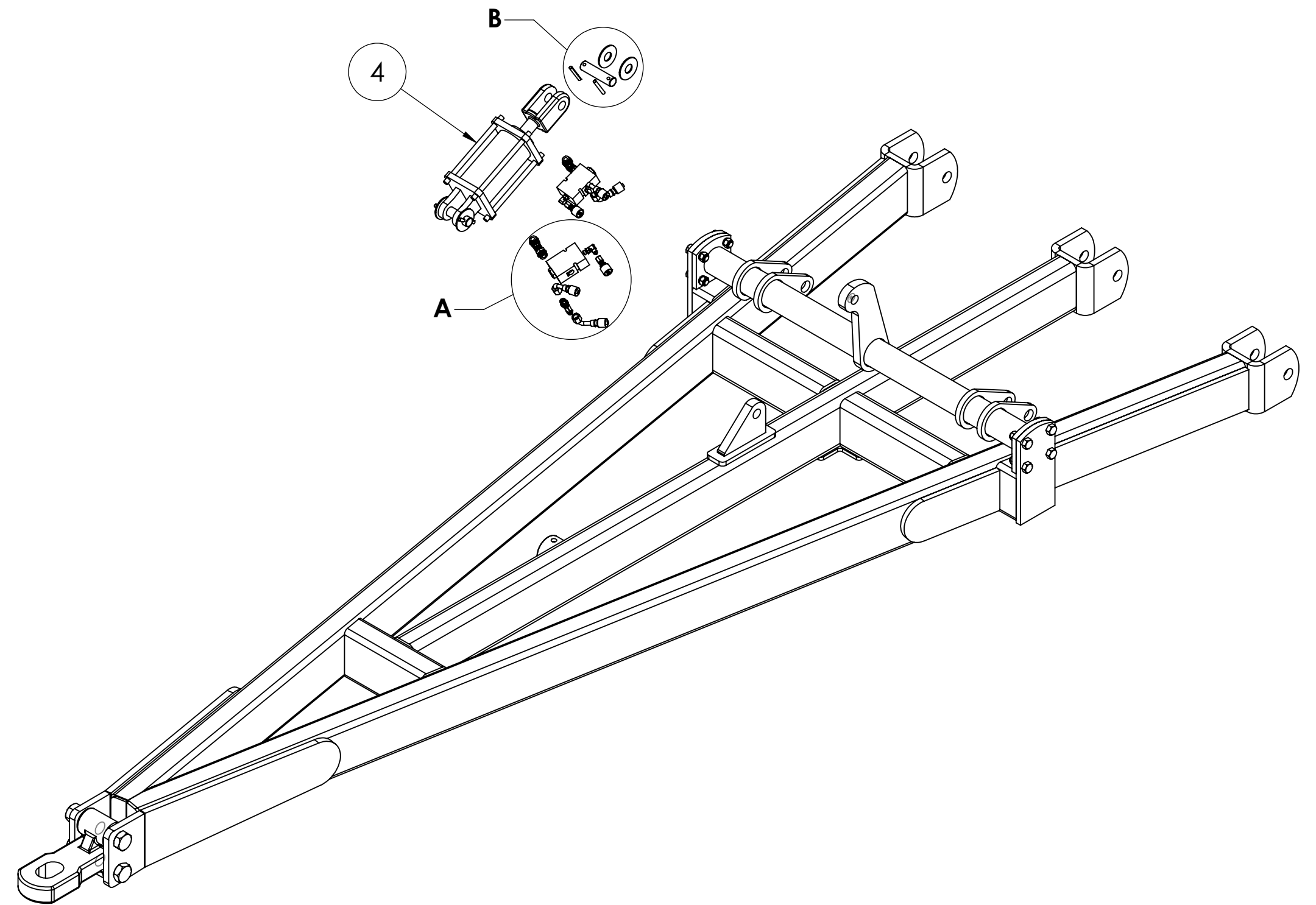
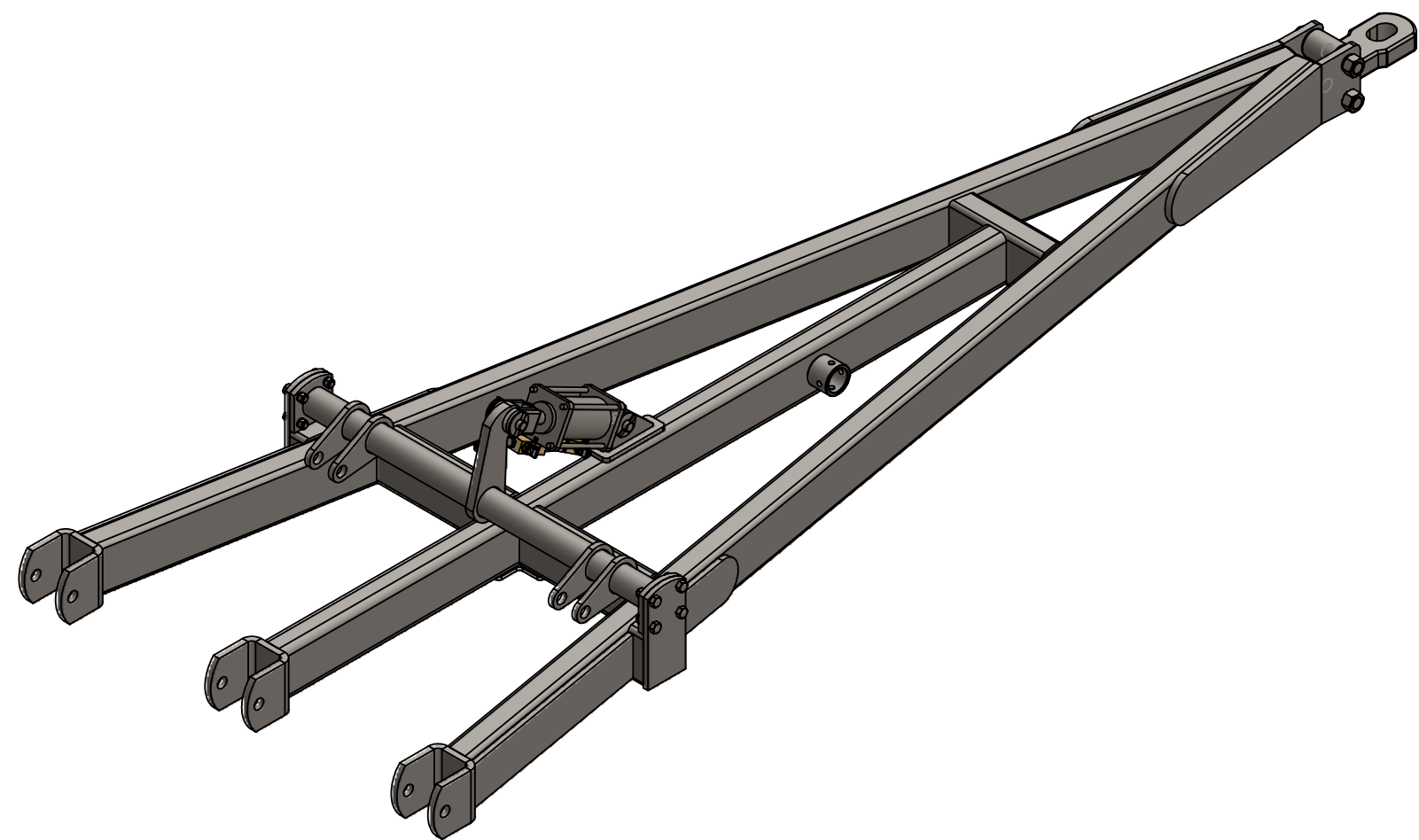
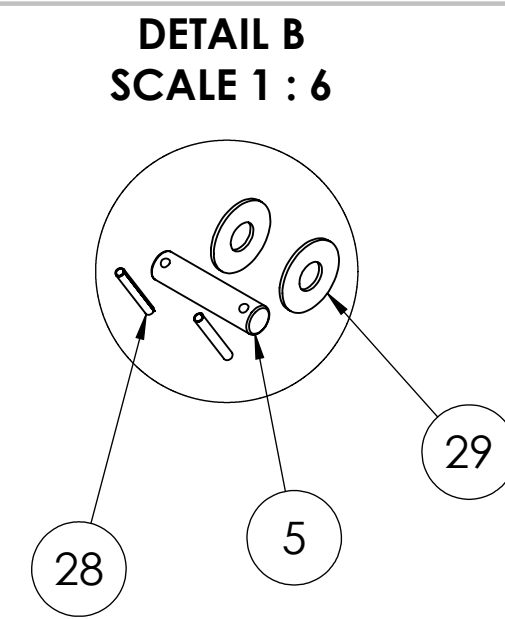
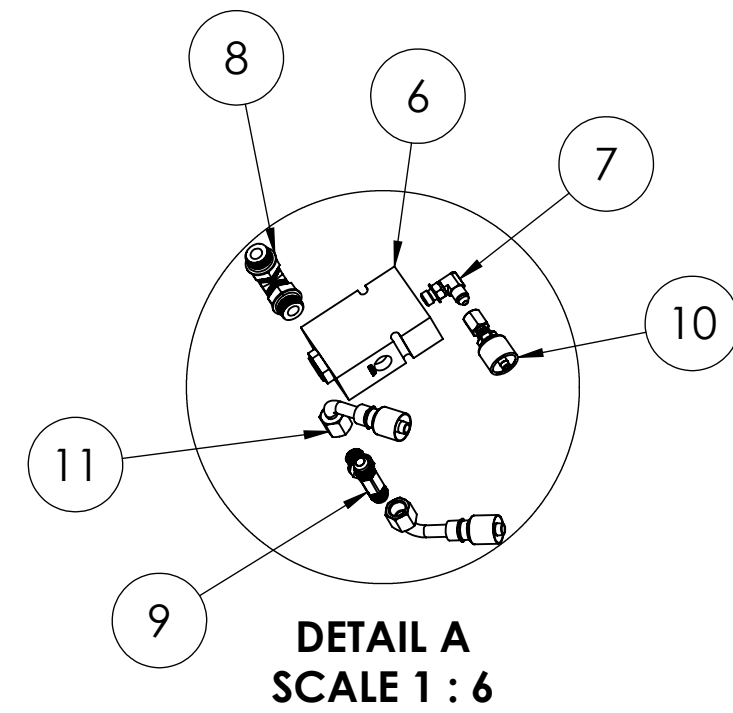

ITEM NO.	PART NUMBER	DESCRIPTION	QTY.
4	MM3500019	3-1/2 X 5 HITCH CYLINDER	1
5	MM3500027	1" x 3.036" PIN LIFT CYLINDER BASE	2
6	330286 VALVE	EATON DPS2-16-P-F-12H VICKERS MANIFOLD VALVE 11962	2
7	4MB-4MJ90	MALE O-RING BOSS TO MALE JIC 37° (90°)	2
8	6MB-6MB90	8MB-8MB90	2
9	6MB-6MJT	9/16 - 18 MALE O RING TO 9/16 - 18 MALE JIC TEE	2
10	4G-4FJX	STRAIGHT FEMALE JICE 37° FLARE SWIVEL MEGACRIMP G25 COUPLING	2
11	8G-8FJX90S	90° Bent Tube Female JIC 37 Degree Swivel Megacrimp G25 Coupling	4
28	150006	5/16" x 2-1/2" ROLL PIN	4
29	150170	1" SAE FLAT WASHER	4